

KOWA

MAINTENANCE TOOLS CATALOG 2016

KOWA SEIKI CO.,LTD.



KOWA recommended SHOW ROOM!!



We make a comfortable working space come true.

We propose a factory layout to fit the needs of our customers.

Feel free to contact us.

Before Using Our Products

First, we wish to express our gratitude to all of you for your selecting our product. We have edited a catalog including Motor Cycle maintenance machines, tools and testers.

The instruments of Motor Cycle maintenance require the format and functions matching the specialty. This catalog summarizes achievements made by pursuing how the instruments of Motor Cycle maintenance should be, making research and development. We introduce "KOWA Original" uniquely developed based on the know-how and excellent products we have carefully selected so that we can recommend them with confidence in the quality and functions.

Classification and Product Numbers

This catalog classifies machine, tools and testers according to application. A series of product numbers are given to products described by group and are used to manage products.

Placing an Order and Inquiry

1. Check the product number, mode, product name and specification described on the catalog before placing an order and making an inquiry.
2. Place an order to the overseas sales division of KOWA SEIKI.
3. Products may be shipped by selecting the safest and fastest method if not specified. The cost of shipping, installation and test operation should be paid by the customer.
4. If you have a question on a damage, wrong product, quantity, price and model, make an inquiry to us within 7 days. The product may be refused to accept in principle if it is returned to us over one month.

Specification and Price

Please take note that the models, specifications and prices of products described in this catalog are subject to change without notice due to improvement and design change of the products. Your questions and requests on this catalog are welcome.

KOWA SEIKI CO., LTD.

TEL: +81-3-5822-0855 FAX: +81-3-5822-0850
7F Miyata-Kinzoku Building, 2-15-18 Misuji, Taito-ku,
Tokyo JAPAN
Zip Code 111-0055

KOWA SEIKI (THAILAND) CO., LTD.

TEL: +66-2673-9933 FAX: +66-2673-9993
26 Soi Chan 32 Yak 2, Tungwatdon, Sathorn, Bangkok
THAILAND
Zip Code 10120

Low-Platform Bike Lift

Low Floor Squeezed to 115 mm Limit

The minimum height from the ground has been squeezed to the limit at 115 mm to make it easier to mount motorcycles. The maximum height from the ground at which work can be carried out without crouching is 1200 mm. Table size is a perfect fit at 800 × 2250 mm. Equipped with 4-stage drop prevention safety device to ensure work is carried out safely.

The large, wide slope is detachable for easy mounting. Equipped with storable tire remover for easy attachment and removal of rear wheels. A space-saving, low noise, built-in electric unit has been adopted in consideration of the environment.

The safety lock release mechanism has been upgraded to a handle type. The lock mechanism is the same as the conventional claw lock type, meaning no concerns over safety.

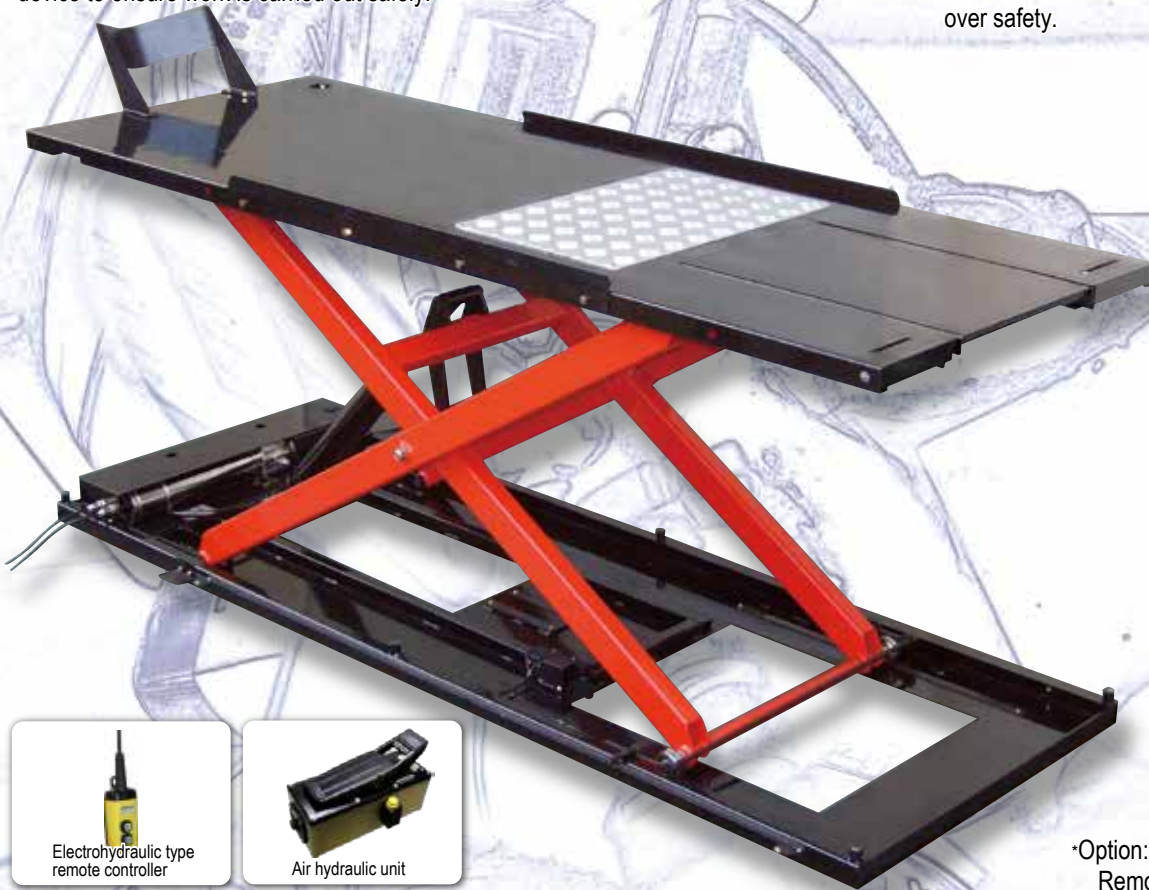

Electrohydraulic type remote controller

Air hydraulic unit

*Option:
Remote controller reel
Can also be fitted to medium-size lifts

Lower, and Higher

Max. height: 1200 mm

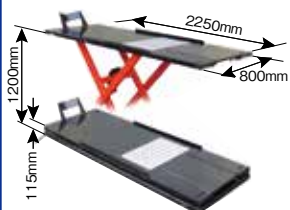

Safer

4-stage drop prevention safety device

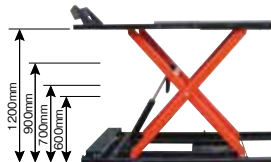

Easier to Use

Storable rear wheel remover

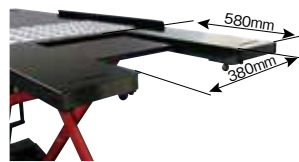

Detachable wide slope

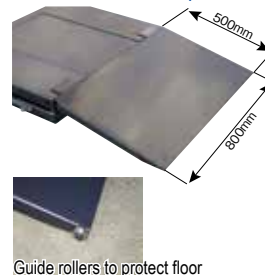

Further Space-saving

Built-in electrohydraulic unit



Even Safer

KBK-50-LB100CL
Option: Front wheel clamp

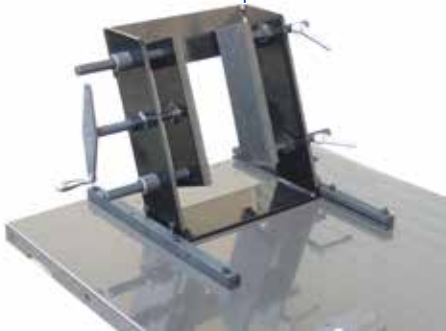

Specifications

Part No.	KBK-50-LB100EN	KBK-50-LB200VN
Basic table size	800 (W) × 2250 (total length) + 500 mm (slope)	
Max. lift height	1200mm	
Min. height from the ground	115mm	
Lifting capability	600kg	
Lift time	Approx. 2 min. 40 sec.	Approx. 40 sec.
Drop prevention safety device	Hand release type (locked at height from the ground of 500, 700, 900, 1200)	
Weight	245kg	255kg
Motor	Air hydraulic type, air pressure: 0.8 to 1.0MPa*	Electrohydraulic type: 200 VAC, electric type (single-phase)
Operation method	Foot-pedal type	Wired remote controller (cable length: approx. 3 m)

* A separate air hydraulic unit is provided with air hydraulic specification lifts.

● Please be aware that specifications may be subject to change without prior notice.

⚠ CAUTION: Always read the "Instruction Manual" beforehand to ensure safe and correct use.

Please ask your dealer or a professional contractor to carry out installation work. Failure to carry out installation correctly may lead to accidents.

Chassis Dynamometer for Motorcycles

Max. Measured HP of 600 PS

Measurement is possible up to 600 ps for big bikes.
Automatic measurement is now possible by hooking up to a computer.
Moreover, detailed measurement of the vehicle status is now possible with additional options.
Measurement is possible up to 360 km/h.



Front Clamping Device Max. clamp width: 185 mm	Cooling Unit Built into clamp
Stable Double Roller and Support for 2000 mm Wheelbases Roller width: 450 mm	
Further Space-saving	Colorful Screen Layouts, Data Saving

* Sensors for air-fuel ratio, etc. available as option.

Specifications

Part No.	KNK-50-SD500
Max. HP measurement	600ps (441kw)
Max. torque measurement	490N·m (50kgm)
Max. speed measurement	360Km/h
Front clamp width	185mm
Max. wheelbase	2000mm
Roller dia., width	ø318·450mm
Weight	550kg
Size	810 (W) × 2910 (total length) × 860 (H) mm
Power supply	100 to 230 VAC

- Please make inquiries at your local Kowa Seiki office.
 - Please be aware that specifications may be subject to change without prior notice.
 - ⚠ CAUTION: Always read the "Instruction Manual" beforehand to ensure safe and correct use.
- Please ask your dealer or a professional contractor to carry out installation work. Failure to carry out installation correctly may lead to accidents.



Medium-size Bike Lift 200 V Electric Type

Unparalleled operability with 500/600/700/800 mm 4-stage lock mechanism.

Specifications

Part No.	KBK-50-200THI
Basic table size	700 (W) × 2100 (total length) × 500 (H) mm (externally attached slope)
Max. height from the ground	1000mm
Min. height from the ground	160mm
Unloading capability	400kg
Lifting capability	Approx. 20 sec.
Weight	Approx. 190kg
Drop safety unit	Hand release type (locked at height from the ground of 500, 600, 700, 800)
Motor	Electrohydraulic type, single-phase 200 V (built-in)
Operation method	Wired remote controller
Standard accessories	Front wheel stopper, wired remote controller (3 m), power cable (3 m), side rail

- Please make inquiries at your local Kowa Seiki office.
 - Please be aware that specifications may be subject to change without prior notice.
 - ⚠ CAUTION: Always read the "Instruction Manual" beforehand to ensure safe and correct use.
- Please ask your dealer or a professional contractor to carry out installation work. Failure to carry out installation correctly may lead to accidents.

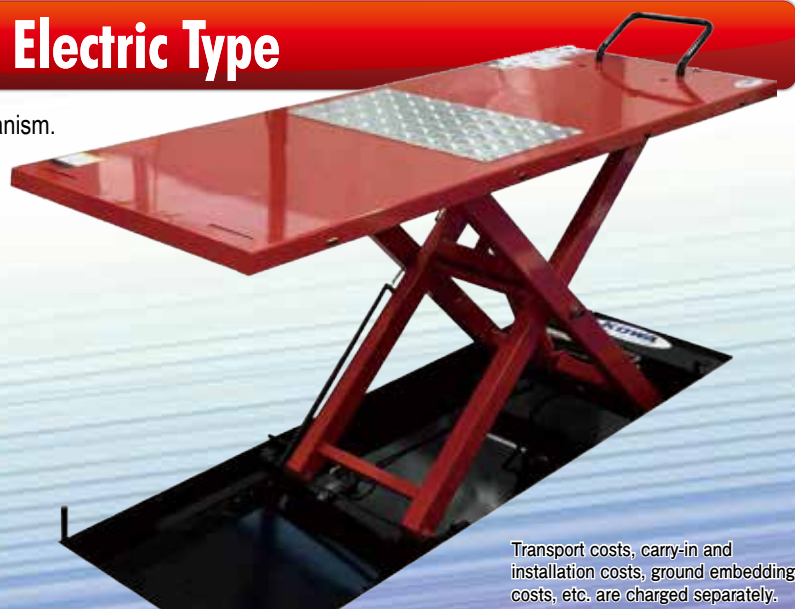

Transport costs, carry-in and installation costs, ground embedding costs, etc. are charged separately.

Certified Instruments and Tools for Motorcycles

Parts Washer KA-3-TRG440



External size: 758 (W) × 525 (D) × 875 (H) mm
Sink size: 745 (W) × 515 (D) × 235 (H) mm
See P7.

Tire Gauge with Hands-free Chuck KFK-2-29

The L-shaped clip chuck can be easily fitted to air chucks on small-diameter wheels on the likes of motorcycles and scooters with large disk rotor.
Measurement range: 50 to 500kPa
With connection coupler



See P13.

Tire Gauge with Chuck for Motorcycles KFK-2-24

Air can be easily pumped, measured, and released.
Measurement range: <50 to 500kPa>

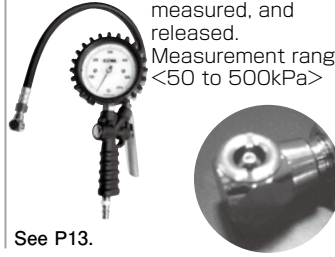

See P13.

Grease Gun 200 cc KC-9-1

Grease Gun 120 cc KC-9-2



See P9.

This can be used not only for motorcycles, but also tire changers and bike lifts, etc.

Battery Charger with Sulfation Recovery Function (12 V) KF-15-P2020EV2



See P14.

Battery Density Gauge (Small) KF-17-1



Total length: 270 mm

See P14.

Analog Circuit Tester KE-32-KF32



See P10.

Dial Gauge KK-14-1



Measurement range: 0 to 10 mm
Minute scale: 1/100 mm
Size: 52.5 mm

See P18.

Handy Vacuum Pump Set KE-21-8000J



All locations that operate under negative pressure can be checked and tested. See P11.

PITA Micrometer Caliper 200 mm KK-2-PITA



The end face of the caliper has been cut. These revolutionary new calipers have a flat head.

See P18.

Compression Gauge Set KEK-20-100

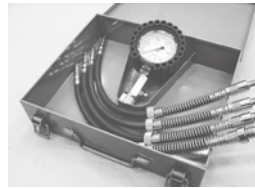

- Cylinder internal compression leakages can be accurately verified.
- Plug hole screw flexible ATT can be easily installed. Measurement range: 0 to 2500kPa
With 8, 10, 12, 14 mm flexible ATT

See P11.



Thickness Gauge 100 × 12.7 KK-8-4



Size: 100 mm
Measurement range: 0.04, 0.05, 0.06, 0.07, 0.08, 0.1, 0.15, 0.2, 0.3

See P18.

Preset Torque Wrench N1400QLK KK-18-10



N1400QLK 1/2SQ
Measurement range: 40 to 140 N·m
N450QLK 3/8SQ
Measurement range: 10 to 45 N·m

See P17.

Vice KL-30-7 (Applied Type) KL-30-3 (Lead Type)

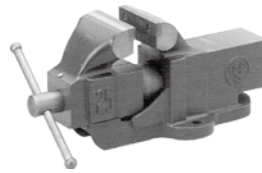

The applied type is incredibly durable. Width: 125 mm

See P34.

CO/HC Tester MEXA324L KN-27-MEXA324L



The self-diagnostic result is indicated with symbol marks.

See P36.

Reciprocating Air Compressor KG-1-W37P

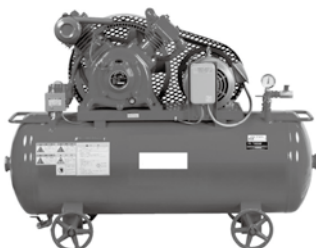

* Transport costs, installation work, and foundation work are charged separately.

See P14.

Package Air Compressor KG-1-NLPW37P



* Transport costs, installation work, and foundation work are charged separately.

See P14.

Package Compressor (Built-in Dryer) KG-1-NLPW37PRD



* Transport costs, installation work, and foundation work are charged separately.

See P14.

Specific Equipment Instruments

Motorcycle Diagnostic Instrument (High Grade) 160 km/h Specification
KNK-50-160

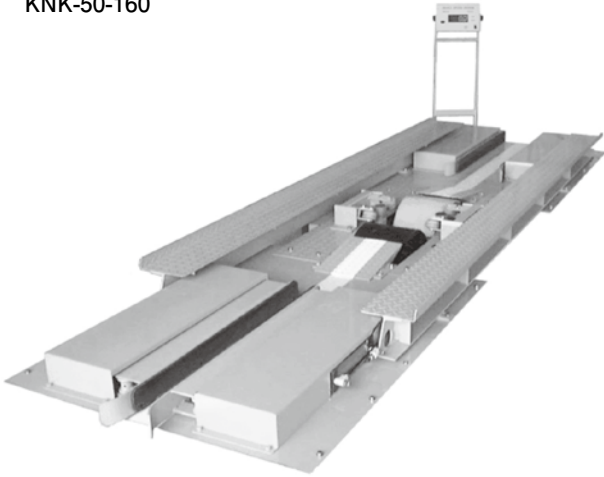

Speedometer tests are possible for high speeds.
This new motorcycle diagnostic instrument employs the latest electronic technology.
Operation is performed with a wireless remote controller.
* Transport costs, installation work, and foundation work are charged separately.

See P35.

Motorcycle Diagnostic Instrument (Standard) 80 km/h Specification
KNK-50-40K

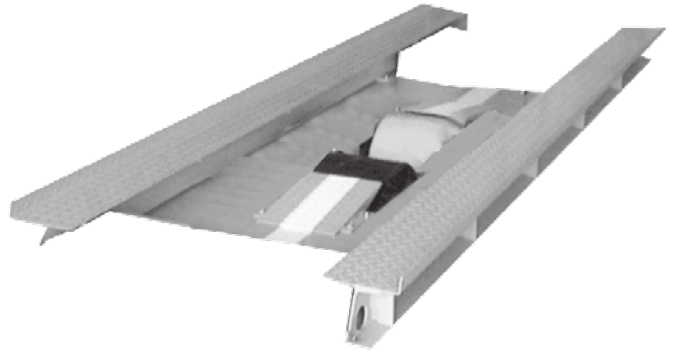

This new motorcycle diagnostic instrument employs the latest electronic technology.
Operation is performed with a wireless remote controller.
* Transport costs, installation work, and foundation work are charged separately.

See P35.

Head Light Tester
KN-5-IM2713



See P6.

Low-Platform Bike Lift
(Electrohydraulic)
KBK-50-LB200VN



See P2, 8

Wheel Balancer for Motorcycles
KF-2-B100NKW2



With dedicated device for motorcycles,
standard ATT.
Motor driven.

See P12.

Digital Tester
(Coil Capacitor Tester)
KE-32-RD701

True effective value measurement



	Measurement range	Resolution
DC voltage/AC voltage	400 mV/4/400/1000 V	0.1 mV
DC current/AC current	400 μ/4000 μ/40m/400m/4/10A	0.1 μ A
Resistance	400/4k/40k/400k/4M/40M Ω	0.1 Ω
Capacitor capacity	500 n/5 μ/50 μ/500 μ/3000 μ F	0.1 nF
Temperature	-20 to 300 °C	1 °C
Frequency	50Hz to 1MHz	0.01Hz
Conductance	Buzzer sound at 5 to 120 Ω, Open circuit voltage Approx. 0.4 V	

Volume Indicator
KN-9-IM2801



See P36.

Noise Meter
KN-9-NL27



See P36.

Stand for Volume Indicator, Noise Meter

Setting alarm measurement is also possible in one go at 45° and 0.5 m with the arrow mark on the end.



Part No.	KNK-9-STAND	ALH050411-001
Product Name	Volume Stand	Noise Meter Stand
Supported measuring instruments	NL26/NL27	IM2801
Measurement height (mm)	50 to 1,500	190 to 1,000

See P36.

With Oil Bucket Pump Flowmeter
KC-8-5



● Flowmeter (with filter)
● With oil hose nozzle (black, 2 m)
Total height: 795 mm
Capacity: 20 ℓ

Radiator Cap Tester
KE-30-3



Specifications
Filler neck shape: Lock type (hook type) Inner diameter: 41 mm Depth: 19.5 mm, 24.5 mm
See P11.

● Head Light Tester - Manual Image Processing Type KN-5-IM2702

Manual Type with 17-inch Color LCD, Lift Motor

- Large 17-inch color LCD display A large 17-inch color LCD display with outstanding visibility has been adopted for the monitor used to display lamp images, light distribution patterns, and all measurement values.
- Easy contrasting with lamp images Lamp contrasting work is carried out while viewing lamp images taken with a CCD camera, facilitating easy, fast, and accurate lamp contrasting.
- Z beam support In addition to the conventional measurement program, a new program compatible with recently popular Z beam measurement is also provided.
- Own-eye measurement function Now equipped with "own-eye measurement function" used to align elbow points with your own eye while viewing light distribution patterns projected onto the monitor.
- Equipped with electric lift motor as standard Now equipped with a motor used to raise and lower the light receiver with switches rather than with a handle, etc.
- * The explosion-proof specification model is equipped with a handle.
- Equipped with leveling mechanism as standard A light receiver leveling mechanism built into the arm supports the receiver securely, ensuring that it is always kept stable and parallel.



Measurement method	Manual image processing type
Measurement distance (m)	1.0
Light receiver size (mm)	W460×H390×D514
Power supply	AC system (100 VAC, 50/60Hz)
Photometer indicating range (hcd)	High beam brightness: 0 to 1200 Low beam brightness: 0 to 800
Lamp attachment height range (cm)	25~120
Display unit	17-inch color LCD
Lamp contrasting method	Cross laser + CCD camera images
Vehicle contrasting unit	Scope method
Light receiver horizontal check unit	Round spirit level
Measurement distance check unit	Convex rule
Size (mm)	W740×H1322×D510
Weight (kg)	65
Accessories	Cover (light receiver, auxiliary light, LCD) Power cable: 10 m
Options	Printer, running rail, messenger wire

● Head Light Tester - Screen Type KN-5-IM2713

- Equipped with cross laser as standard In addition to lamp contrasting, vehicle contrasting is now also possible with a reliable cross laser easier to use than the conventional point laser.
- Equipped with lamp image window Equipped with lamp image display window compatible with a wider variety of lamp shapes for lamp contrasting for vehicles such as imported or older vehicles with no lamp center mark.
- Lamp attachment height lower limit of 40 cm Attachment height lower limit of 40 cm now possible, while covering the upper limit (120 cm) dictated by safety standards.



Measurement method	Manual screen type
Measurement distance (m)	1.0
Light receiver size (mm)	W460×H490×D404
Power supply	AA-sized battery × 4
Photometer indicating range (hcd)	High beam brightness: 0 to 1200 Low beam brightness: 0 to 800
Lamp attachment height range (cm)	25~120
Display unit	Photometer (LCD display) Illumination direction meter (LCD display)
Lamp contrasting method	Cross laser + Lamp images
Vehicle contrasting unit	Scope method
Light receiver horizontal check unit	Round spirit level
Measurement distance check unit	Convex rule
Size (mm)	W790×H1300×D570
Weight (kg)	55
Accessories	Cover (light receiver, auxiliary light) AA-sized battery × 4
Options	Running rail

Car Washing and Cleaning Machines and Tools

High-pressure Washing Machine KA-3-CS7112DX



Compact body and easy-to-use
Equipped with a stainless boiler
and a no-grease ceramic plunger
* Transport costs, installation work, and
foundation work are charged separately.

Discharge pressure (MPa)	1.1
Pump discharge qty (L/h)	900
Hot water temperature (°C)	Room temp. to 80 °C
Pump	3-piece ceramic Plunger pump (direct motor connection)
Motor	Three-phase 200 V, 2.2kW
Fuel consumption (L/h)	3.2 to 4.8 L/h
Fuel	Kerosene (JIS #1 kerosene)
Fuel tank (L)	20
Boiler	Accumulator type multiple fire-tube stainless steel boiler
Burner	Gun type boiler
Washing hose (adapter size)	Φ 9 × 10 m (3/8")
Freezing prevention unit	Sheath heater 200W Auto heater type
Water feed hose	Φ 15 × Φ 21 × 3 m
Required water qty (L/min)	18 L
Electric capacity (A)	30
Size (mm)	752 × 583 × 1040
Weight (kg)	103

High-pressure Hose for Washing Machine



Length : 10m

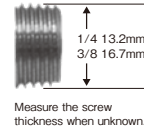

Measure the screw
thickness when unknown.

For 1/4	KA-2-11
For 3/8	KA-2-11A

Stainless Steel Coupler, High-pressure Spin Joint

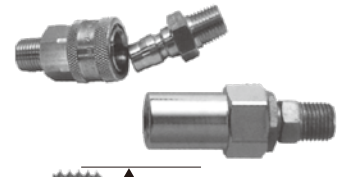

Measure the screw thickness when unknown.

Stainless steel coupler set for 1/4	KA-2-KHK14N
Stainless steel coupler set for 3/8	KA-2-KHK38N
High-pressure spin joint 1/4	KA-2-SSP2N
High-pressure spin joint 3/8	KA-2-SSP3N

Hot-water Reel 10 m KA-6-SOH210P

Attach to the high-pressure
washing machine. Extremely
convenient for storing hoses.

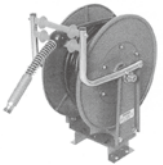

Inner diameter: 8.3 mm
Outer diameter: 13.1 mm
Total length: 10.0 m

With 1.5 m joint hose
H: 430 W: 380 D: 256
Weight: 12.6 kg

Engine Cleaner KA-4-1

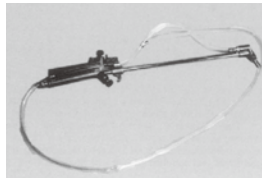

Washing can be performed by drawing up
cleaning detergent, etc. and directing the
jet with air pressure.
It can also be used as an air gun.
Size: 80 × 420 × 20 mm Weight: 500 g

Stainless Steel Oil Pan KA-5-3

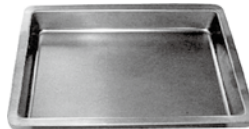

Made entirely from rust-
resistant stainless steel.
Size: 508 × 358 × 56 mm

Steel Oil Pan KA-5-1



Difficult-to-rust oil pan
with bonderized sheet.
Size: 508 × 358 × 56 mm

Magnet Tray KA-5-5



With magnet to prevent
small parts becoming lost.
Size: 200 × 160 × 150 mm

Parts Washer KA-3-TRG440



- External size: 758 (W) × 525 (D) × 875 (H) mm
- Sink size: 745 (W) × 515 (D) × 235 (H) mm
- Power supply (pump): 100 VAC (solvent circulation type)
- Capacity: 150 ℓ

Parts Washer KA-3-TRG435



- Sink size: 415 (W) × 325 (D) × 190 (H) mm
- Power supply (pump): 100 VAC (solvent circulation type)
- Capacity: 13 ℓ

Water Hose Reel KG-4-HAP310JW



Primary side, piping side: R3/8 Reel side: Rc3/8
Primary side outer diameter: 12 mm
Inner diameter: 8 mm Length: 10 m

Water can be supplied easily at any time.
With die cast water sprinkling gun that allows the
pattern to be adjusted freely by altering the grip
strength.

Multi-Polishing System (Used Motorcycle Repair Kit) KHK-2-BK1



Set contents

- Angle polisher
- 75Φ random pad
- 73Φ intermediate cushion pad
- 80Φ wool puff
- 80Φ urethane puff
- 75Φ sanding paper
#120, 180 and 240, one sheet each

- 10 x KOWA blue polish sheets
- 4 x KOWA multi-polishing sheets
- 3M hard 2-compound
- Air regulator
- Case

Front Fork

- Multi-polishing sheet
- Blue polish
- Polisher
- Random pad
- Intermediate cushion pad

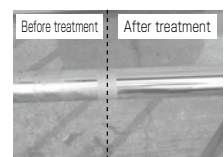
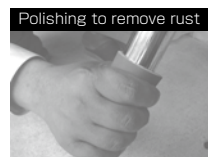

Stainless Muffler

- Multi-polishing sheet
- Blue polish
- Polisher
- Random pad
- Intermediate cushion pad

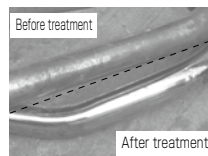

Employing an angle polisher allows rust to be removed and polishing work carried out in tight spaces. Almost all parts of bikes can be cleaned by changing pads.

Lifts, Hydraulic Equipment, Stands

Low-Platform Bike Lift 200 V (Electrohydraulic) KBK-50-LB200VN

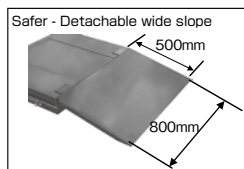
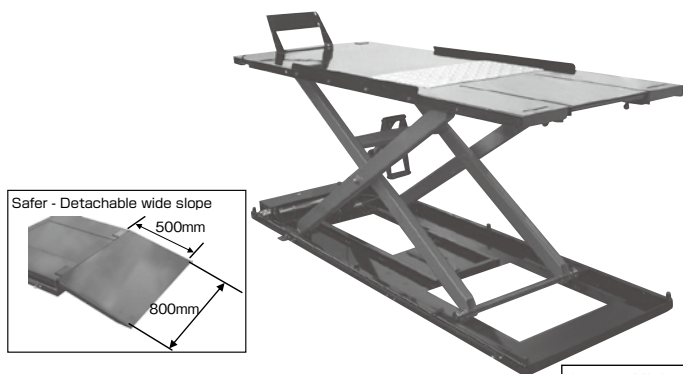

Low-floor Bike Lift (Air hydraulic) KBK-50-LB100EN



Front wheel clamp
KBK-50-LB100CL

Specifications

Part No.	KBK-50-LB100EN	KBK-50-LB200VN
Basic table size	800 (W) × 2250 (total length) + 500 mm (slope)	
Max. lift height	1200mm	
Min. height from the ground	115mm	
Lifting capability	600kg	
Lift time	Approx. 2 min. 40 sec.	40 sec.
Drop prevention safety device	Hand release type (locked at height from the ground of 500, 700, 900, 1200)	
Weight	245kg	255kg
Motor	Air hydraulic type, air pressure: 0.8 to 1.0MPa	Electrohydraulic type: 200 VAC, electric type(single-phase)
Operation method	Foot-pedal type	Wired remote controller (cable length: approx. 3 m)

- Ample table size of 800 (W) × 2,250 (L) mm
- Ultra-low floor of 115 mm from ground realized
- ※ An optional front wheel clamp is available.

(Note) Transport costs and installation costs are charged separately.

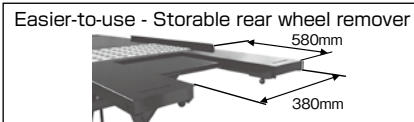
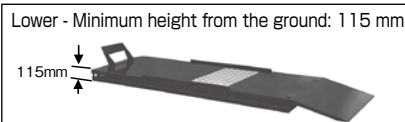

Medium-size Bike Lift 200 V Electric Type KBK-50-200THI



Specifications

Part No.	KBK-50-200THI
Basic table size	700 (W) × 2100 (total length) × 500 (H) mm (externally attached slope)
Max. height from the ground	1000mm
Min. height from the ground	160mm
Unloading capability	400kg
Lifting capability	Approx. 20 sec.
Weight	Approx. 190 kg
Drop prevention safety device	Hand release type (locked at height from the ground of 500, 600, 700, 800)
Motor	Electrohydraulic type, single-phase 200 V (built-in)
Operation method	Wired remote controller
Standard accessories	Front wheel stopper, wired remote controller (3 m), power cable (3 m), side rail

(Note) Transport costs and installation costs are charged separately.

Bike Crane KB-12-3



Length: 700 mm
Height: 1,800 mm
Width: 1,630 mm
Lifting load: 250 kg

* Transport costs, installation work, and foundation work are charged separately.

Center Jack KB-5-MC450

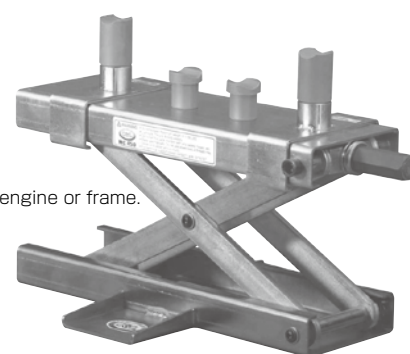

Bikes are supported below the engine or frame.
With frame ATT
Size: 405 × 135 mm
Max. lift height: 330 mm
Min. height: 330 mm
Allowable load: 500 kg

Aluminum Jack 1.5 t KB-5-EM202R



- Lowest position: 85 mm
- Highest position: 375 mm
- Size: 250 (W) × 555 (D) × 150 (H) mm
- Weight: 11.0 kg

Low Down Jack 3.25 t KB-5-T83508



- Lowest position: 98mm
- Highest position: 535mm
- Size: 345 (W) × 780 (D) × 170 (H) mm
- Weight: 44 kg

Lifts, Hydraulic Equipment, Stands/Oiling Equipment

Hydraulic Press 5 t KB-11-1



Hydraulic Press 15t KB-11-2

Part No.	KB-11-1	KB-11-2
Operation	Manual	Manual
Capability (tons)	5	15
Ram stroke	150	160
Auxiliary screw stroke	80	120
Frame inner width (mm)	560	600
Table inner width (mm)	104	142
Table pitch (mm)	520	700
Total height (mm)	1320	1630
Installation area (mm)	760 × 600	860 × 600
Weight (kg)	78	150

Hydraulic Press 12t (Without Meter) KB-11-TY123



- Capability: 12t (no meter)
- Work height: 725 to 515 mm
- Size: 505 (W) × 495 (D) × 1235 (H) mm

Hydraulic Press 12t (With Meter) KB-11-TY122



- Capability: 12t (without meter)
- Work height: 965 to 205 mm
- Size: 695 (W) × 500 (D) × 1660 (H) mm

Carburetor Stand 2K-B-01



For overhauling stand-alone carburetors. Carburetors can be easily secured with a special piece of rubber.
Applicable models: Manifold diameter φ25 to 40

Maintenance Stand KBK-55-1



Cylinder heads can be overhauled with ease. Flexible support for small to large vehicles.

Oil Changer KC-11-EP7000M

Specifications		
Tank	Material	Cold rolled steel sheet, baking finish
	Capacity	76 ℓ
Motor		100 VAC, 200W
Pump		Trochoid gear pump
Sampling tube		-Teflon tube, φ4.57 × φ6.35 × 680 (L) mm
		-Teflon tube with flexible wire φ4 × φ6.5 × L750mm
Suction hose		Dil-resistant hose, Inner diameter φ12.7mm, length 1.85m (total length 2m)
Oil gauge		Float type
Glass tube	Material	Heat-resistant reinforced glass
	Capacity	6ℓ
Size		529 (695) (W) × 529 (D) × 1,158 (H) mm (leg tip max. width)
Weight		37kg

Engine oil can be changed in only a few minutes. Comes equipped with a suction pipe compatible with almost any vehicle, allowing waste oil to be completely replaced with clean oil. This high-performance model can be used to change oil and wash the insides of crank cases and transmissions.



Tire Lifter for Motorcycles KBK-59-5



Tires are raised through the principle of leverage, allowing the vehicle to be moved sideways.

Double Pail Stand HD-001



Size
390 × 390 × 970 mm
With L-type nozzle

Oil Pan Stand KC-51-1



Size
440 × 420 × 640 mm
Weight: 12 kg
* Oil pan sold separately.

Oil Syringe (S) KC-12-LB406



Plastic, compact and lightweight oil syringe. Semitransparent, allowing the quantity to be verified.
Tank capacity: 200 ml
Weight: 250 g

Hayamaru-kun For 18 L Square Cans, 20 L Round Cans KC-8-HY20L



Oil can be supplied continuously from cans without pulsing.
Max. flow: 31.5 L/min.
Size: 120 × 445 × 55
Weight: 250 g

Grease Gun 200 cc KC-9-1

Grease Gun 120 cc KC-9-2



This can be used not only for motorcycles but also tire changers and bike lifts, etc.

Pump for Pale Can KC-10-JW1461

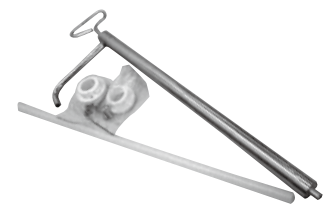

- 1 stroke 220 cc

Long Nozzle Oil Jug

With 50 cm long nozzle for easy filling even from a distance.



Long nozzle oil jug 3 ℓ	KC-14-3230
Long nozzle oil jug 4 ℓ	KC-14-3240
Long nozzle oil jug 5 ℓ	KC-14-3250

Oil Bucket Pump for Pale Cans KC-8-8A

With this simple bucket pump, commercial 20 L cans are used to supply oil by loading them directly onto a trolley and fitting the pump.
* Does not include flowmeter.

Hose for bucket pump	KC-8-S10
----------------------	----------



Syringe KC-20-SD101

For adjusting oil quantity.

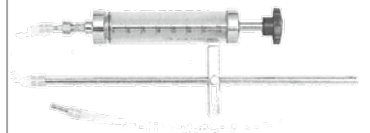

Measuring Instruments

Mecha Mate VII KEK-32-16S

- Battery voltage measurement
- Alternator charging current measurement
- Rotation speed measurement
- Injection pulse width measurement
- Air conditioner outlet temperature measurement
- Measurement of all sensors

■ Support for all kinds of electric checks



Battery voltage measurement



Rotation speed measurement



Definitive Comprehensive Diagnostic Tester for Motorcycles

Measurement Specifications

DC voltage	60.00 mV to 1000 V
AC voltage	60.00 mV to 1000 V
DC current	600 μ A to 10.00A *1
AC current	600 μ A to 10.00A
Resistance	600.0 Ω to 60.00M Ω *2
Rotation speed	240 to 20,000 rpm
Dwell angle	0.0° to 360.0°

*1 10A can be measured within 30 seconds.
*2 Value for 4 cycles, when using rotation sensor.

Function

Backlight	Auto power OFF
Bar graph	Range hold
Wrong insertion prevention function	Display hold

General Specifications

Display	6000 count, character height 20 mm
Power supply	1.5 V R03 (AAA) batteries x 2
Power consumption	13mW (when backlight OFF)
Battery life	Approx. 360 hours (when using alkaline battery)
Size, weight	161 (H) x 80 (W) x 50 (D) mm, 340 g
Accessories	100-6 test leads, holster, 653 rotation sensor (for direct ignition), 654 rotation sensor (for high-tension cable), 818-02 temperature probe, 943 alligator clips, 1024 carrying case, 1.5 V R03 batteries x 2 (built-in), F20 spare fuse (0.63A/500 V) x 1, F32 spare fuse (6.3A/500 V) x 1

Rev Counter Mecha Mate VI KEK-8-6

Compact and lightweight with simple mechanism

Measurement antenna
The tip of the antenna is pressed against high-tension cables or plug caps to measure.

LCD display
Displays measurement values. Values are displayed in a minimum of 10 rpm units with a 5-digit display.
Max.: 19900 rpm
Min.: 10 rpm

Size	130x40x30mm
Meas. item	Engine speed
Power supply	AAA-sized battery x 2

Button operation
(1) POWER Turns power ON/OFF (Press for 4 sec. to turn OFF)
(2) SELECT
Button A: 2 cycles
Button B: 4 cycles



Tester with Rev Counter Mecha Mate V KEK-8-241P

(Also ideal for generators)

Measurement range
Rotation speed: 100 to 19,900 rpm
Voltage: 0 to 200 VDC
Resistance: 0 to 300 Ω

Measurement item	Range	Accuracy	Min. unit
DC voltage (V)	0 to 20 V	$\pm 1\% + 2$ digits	0.01 V
	0 to 50 V	$\pm 1\% + 2$ digits	0.1 V
Resistance, conductance test	51 to 200 V	$\pm 2\% + 2$ digits	0.1 V
	0 to 300 Ω	$\pm 3\% + 5$ digits	0.1 Ω

Storage temp., humidity	0 to 40° C, 80% RH
Power consumption	1mA (approx. 3 mV)
Power supply	1.5 V, AAA-sized battery x 2
Size	48 x 180 x 30 (mm)
Weight	220 g

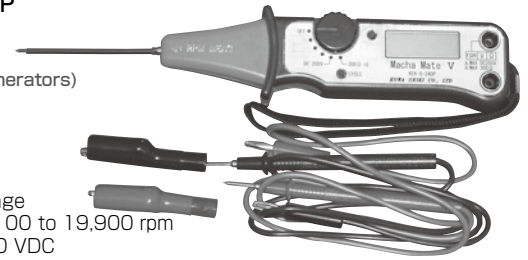

Voltage Tester (Pen Type Digital Multimeter) KE-32-SK6592



MEASUREMENT SPECIFICATIONS
DC voltage: 400.0 mV to 600 V
AC voltage: 4.000mV to 600 V
Resistance: 400.0 Ω to 40.00M Ω

FUNCTION
Max./min. value deviation measurement
Auto power play
Display hold

Size, weight	179 (H) x 28 (W) x 20 (D) mm, 60 g
Accessories	100-52 test leads, 1006 carrying case, 3 V CR2032 battery x 1 (built-in)

Flexible Scope KK-20-WFXS032M45

LENS DIAMETER Φ 4.5 mm 2 m
Image sensor: CMOS
Pixel count: 640 x 480 (PAL/NTSC)
Viewing angle: 45°
Power supply: AAA-size battery x 1
Battery life: Approx. 2 hours
Display: 2.7-inch TFT
Size: 241 x 92 x 50 mm
Weight: 41.6 g

This handy scope projects hidden spots including high places and narrow gaps.



Digital Tester KE-32-KU2600



Multi-function and low cost realized.
600 VDC
600 VAC
10A DC
10A AC
40M Ω

Analog Circuit Tester KE-32-KF32

This analog circuit tester for motorcycles is ideal for measurement and diagnosis of resistance values for ECUs, sensors, and batteries. Selection in the voltage range is possible, and resistance values for 3 V, 12 V, and 30 V can be verified in detail.
DC voltage: 0.3 V, 12 V, 30 V, 120 V, 300 V, 1200 V
AC voltage: 12 V, 30 V, 120 V, 300 V, 1200 V
DC current: 0 μ A to 12A
Resistance: 0 to 5M Ω
Power supply: AAA-size battery x 1
Accessories: Test leads, carrying case, AAA-size battery x 1, built-in fuse (0.75/250 V)



Noise Catcher KEK-7-1

For abnormal noise diagnosis
Noise from all parts can be diagnosed accurately wither either headphones or LEDs.

Standard use	Unit	Magnet sensor (L/R)
		Magnet and clip sensor (L/R)
		Extension cable 3 m (L/R)
		Headphones
Specifications	Case	AAA x 8
	Width	100 mm
	Length	160 mm
	Thickness	50 mm
	Power supply	AAA x 8



Stacking Test Probe KEK-32-20A



Sharp and compact probe. The fine, needle-like tip fits into gaps between wiring couplers, and can be connected to your tester.

Specifications
· 1 each of red/black probe wires
· 2 bent probe tips
· Clip type earth

Peak Voltage Adapter KEK-54-9-B



· Used to measure motorcycle ignition system (ignition coil, pulse generator, CDI unit, etc.) output.

Measuring Instruments

Digital Vacuum Gauge for 4 Cylinders/6 Cylinders

A simple and easy-to-view LCD allows negative pressure to be measured with a rubber hose from the bottom of the gauge body. It comes equipped with a strap that allows it to be hung anywhere.

- * Attachments for measurement are sold separately.
- Size: 170 × 90 × 30 mm
- Measurement range: 40KPa to 80KPa (negative pressure)
- Power supply: 12 VDC



Part Name	Part No.
Digital vacuum gauge for 4 cylinders	KEK-55-64
Digital vacuum gauge for 6 cylinders	KEK-55-66

Analog Vacuum Gauge

KE-55-101A

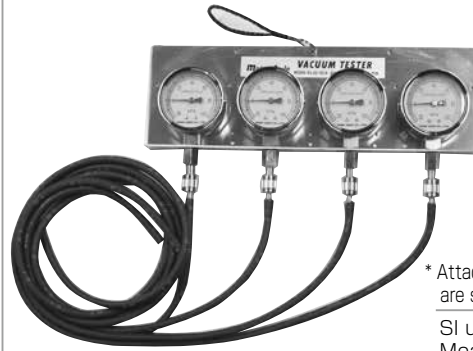

* Attachments for measurement are sold separately.

SI unit display. With hose. Measurement range: 20 to 100KPa

Vacuum Tester ATT (A)

KE-55-1A

Size: M5 × 0.8 L = 169 Set of 2



Vacuum Tester ATT (B)

KE-55-1B

Size: M5 × 0.8 L = 99 Set of 2



Vacuum Tester ATT (C)

KE-55-1C

Size: M6 × 0.75 L = 53 Set of 2



Vacuum Tester ATT (D)

KE-55-1D

Size: M6 × 1.0 L = 60 Set of 4



With Fuel Pressure Indicator Attachment Ø6, Ø8 mm Case

2K-E-H000

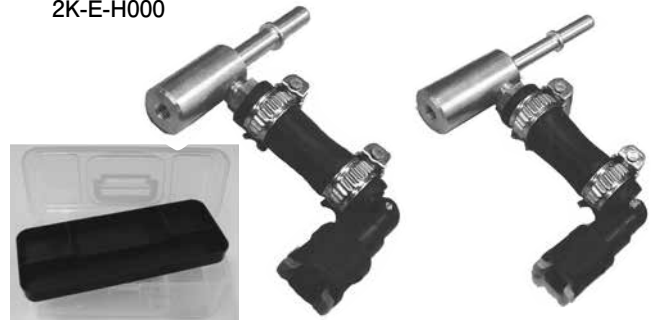

Compatible with quick connectors used with fuel lines. This measuring instrument is indispensable for fuel pressure measurement. These Ø6 and Ø8 attachments are compatible with almost all HONDA vehicles.

Compression Gauge Set

KEK-20-100

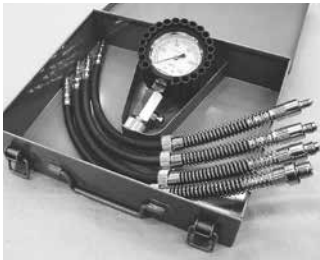

This is a new compression gauge for cylinder internal compression pressure, one of the key engine adjustments. All gauge types are flexible, and unlike previous models, can be used in tight spaces.



Component parts Gauge, ATT 8, 10, 12, 14 mm

Features

- The gauge scale indicates both kg/cm² and SI units (international standard). Moreover, the gauge is fitted with a rubber protector for protection, and employs a push-type mechanism allowing air to be released with a single touch, making this a very easy-to-use instrument.
- Measurement range: 0 to 2500kPa

Compression Gauge ATT (* For Dio/TODAY M10)

KEK-20-112SC



Use KEK-20-100 or KEK-20-5FG for meters for Dio (AF62, AF68)/TODAY to which it is difficult to fit attachments.

Compression Gauge ATT (* For M10 Half Screw Plugs)

KEK-20-112EH



Use KEK-20-100 or KEK-20-5FG for M10EH plug meters.

Compression Gauge ATT (* For M8 Half Screw Plugs)

KEK-20-111EH



Use KEK-20-100 or KEK-20-5FG for E plug (M8) meters.

Compression Gauge ATT (* For M10 Long Reach Plugs)

KEK-20-112LR



Can be used for FORZA (MF10), FAZE (MF11), etc. Use KEK-20-100 or KEK-20-5 for meters.

Compression Gauge

KEK-20-5FG



Now even easier-to-use with hooks and meter flanges for hooking onto an analog meter. Measurement range: 0 to 2500kPa Attachments sold separately.

Handy Vacuum Pump for Negative Pressure

KE-21-8000J

Handy Vacuum Pump for Negative Pressure/Compression

KE-21-8050J



Radiator Cap Tester

KE-30-3



Specifications Filler neck shape: Lock type (hook type) Inner diameter: 41 mm Depth: 19.5 mm, 24.5mm

Ignition Checker

KE99X-010



Makes ignition coil quality judgment easy.

Tire Instruments

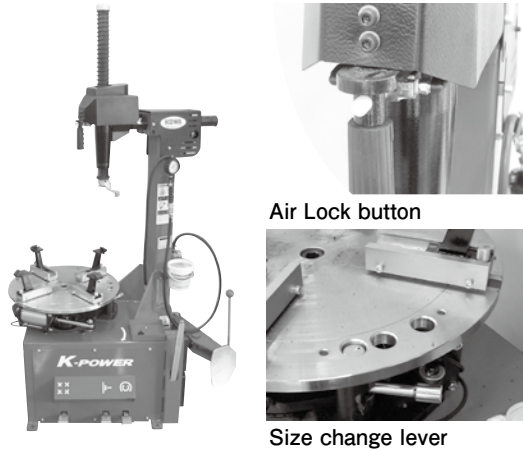

Tire Changer 100 V for Motorcycles
KF-52-100VR

Tire Changer 200 V for Motorcycles
KF-52-200VR

Compatible with 8-inch to 21-inch tires. The power supply can be selected from an easily-installed 100 V or 200 V specification household power supply. A convenient, low-cost air-locking mechanism is employed to secure the arm. A compact design allows the changer to be located anywhere.

* Please indicate 100 V or 200 V when placing your order.

* Transport costs and installation costs are charged separately.

Item	
Applicable rim diameter (external tightening)	8 to 21 inches
Applicable rim width	1.2 to 6.5 inches
Applicable tire diameter	330 to 750 mm
Applicable tire width	55 to 220 mm
Air pressure	0.8 to 1MPa
Power and drive system	100 VAC, 50/60Hz, 400W
	Three-phase 200 V, 0.75Kw
Size	1230 (W) × 1870 (H) × 650 (D) mm

Tire Changer

KF-11-NSW○○

New-generation Changer Catering to Tire and Wheel Diversification
Equipped with Attachment for Bikes

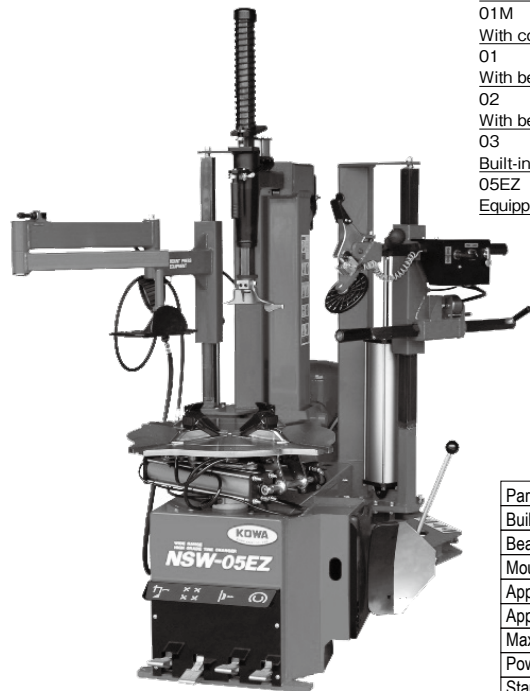

- 00 Standard type
- 01M With compact press
- 01 With bead press device
- 02 With bead press/mount press device
- 03 Built-in inflator, fully-equipped model
- 05EZ Equipped with leverless device

▼Tire fitting with bead press



Support for low-profile tire fitting with use of both bead press and mount press devices.

▼Chucking support with rim press



▼Lower bead lift support

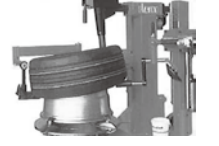

▼Horizontal arm - square shaft ▼Built-in inflator

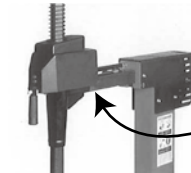

Mount head shifting is minimized during replacement work with the adoption of a square shaft for the horizontal arm.

▼Plastic mount head



Aluminum wheel replacement can be carried out with peace of mind with this plastic mount head.

Part No.: KF-11- (codes on right)	NSW00	NSW01M	NSW01	NSW02	NSW03	NSW05EZ
Built-in inflator	—	○	—	—	○	○
Bead press device	—	—	○	○	○	○
Mount press device	—	—	—	—	○	○
Applicable rim diameter	10 to 22 inches					
Applicable rim width	3.5 to 13 inches					
Max. tire size	860 (Dia.) mm, 320 (W) mm, 1,100 × 350 mm					
Power supply, moto	Three-phase, 200 V, 0.75kW					
Standard accessories	Hand gauge, tire lever, slider cover, bead protector, shoulder protector					

* Transport and installation costs are charged separately.

Wheel Balancer for Motorcycles

KF-2-B100NKW2

7 types of weight mode

The weight attachment position can be selected freely based on the wheel shape or customer's wishes.

Safe operation is ensured with this low revolution type hand spin balancer.

Comes with attachment compatible with almost all motorcycles.

An attachment for cantilevered wheels is optional.

* Transport costs and installation costs are charged separately.



Measurement method	Double-sided concurrent measurement/VPI system	
Rotation method	Motor drive	
Measurement mode	Normal/Static	
	Aluminum/HIDDEN/Matching	
Indication method	Weight	Digital display
	Position	Position display with LED
Measurement wheel	Rim diameter	Normal/Aluminum/Static 10" to 30"
	Spoke/PAX	12" to 25"
Max. tire size	Rim width	3" to 20"
	Outer diameter	35"
Measurement time	Weight 70kg(with wheel)	
Measurement rotation speed	Approx. 6 seconds	
Measurement accuracy	Normal	100 rpm or less
	Fine	Min. 5 g
Braking method	Min. 1 g	
Shaft diameter	Automatic brake	
Power supply	40 mm square screw	
Size	100 VAC, 50/60Hz (0.12kW)	
Weight	690 (L) × 450 (W) × 980 (H)	
	Approx. 70 kg	

Tire Instruments

Tire Gauge with Chuck for Motorcycles KFK-2-24

Air can be easily pumped, measured, and released.
Measurement range: <50 to 500kPa>



With connection coupler

Tire Gauge with Hands-free Chuck KFK-2-29

The L-shaped clip chuck can be easily fitted to air chucks on small-diameter wheels on the likes of motorcycles and scooters with large disk rotor.
Measurement range: <50 to 500kPa>



With connection coupler

Air Spacer KF-3-SP110

"Excellent durability" "Compact size" "Safe design"

Capability range: 25 to 600kPa
Min. scale: 10kPa
Allowable error range: ± 10 kPa
Size (tank): 675 (H) \times exterior $\Phi 275$ mm
(Stand): 645 (H) \times exterior 280 \times 280 mm
Weight (tank): 4.85 kg (Stand): 1.65 kg



Air Chuck for Motorcycles KF-6-4LW



It has two valve openings facing in both directions, and is convenient for large motor scooters. With coupler.

Air Chuck (Double) KF-6-5



Can be used for both bicycles and motorcycles. The coupler is sold separately.

Tire Gauge Holder KF-2-AGHLD



This is a dedicated powerful magnet type holder for tire gauges. It is used to safely store tire gauges for when there is no space for them.

Bead Helper for Super-flat Tires KF-25-50201



It may not be possible to use these for some aluminum wheels depending on the design, etc.

Tire Lever KF-10-H070072

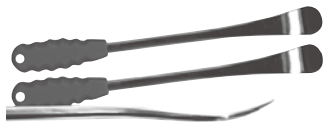

Ideal when working with small tires.

Bead Up Tire Lever KF-10-TL515

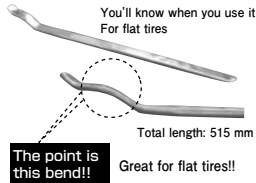

For super-flat tires
Total length: 515 mm

Tire Bead Lever KF-10-TT



This lever is used to prize open the bead section where fingers can be jammed when inserting and removing tire tubes.
Total length: 330 mm

Rim Protector Set of 3 KF-10-1002



Applicable rim range: 16 to 23 inches
Great for preventing rim scratches when replacing tires.

Tie-down Belt KF-10-3030151



- 38 mm \times 1800 mm Set of 2
- Color: Red

Fluid Stopper KF-21-LB303

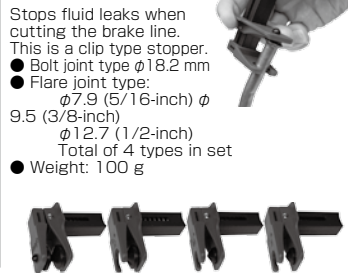

Brake Fluid Tester KFK-21-1



- Brake fluid quality judgment
- Water quantity check
- Prevention of paper lock phenomenon
- Brake system corrosion prevention
- Temperature, humidity range: 0 to 40 °C, 80% RH

Flare Nut Wrench 8 \times 10 mm 2K-F-02



At 9.5 mm for managing torque when attaching and removing brake pipe flare nuts on bikes with ABS.
Total length: 115mm

Wheel Protector KF-9-WP1



Ideal for protecting wheels when attaching or removing tires, and for protection when securing wheels with the tire changer.
Applicable wheel size: 10 to 16 inches (1 protector)
Set contents: Set of 3

Negative Pressure Type Brake Breeder KF-21-QS2119K

Brake air release is easy!
Fast! Excellent stability with large-capacity 1.8 L tank.



Also comes with a complete set of spare parts such as hoses. With 1 m silicon hose

Brake Breeder KF-21-KOP110



Capacity: 1,000 ml

Pry Bar Set of 4 KL-2-PB04N



Set of 4 for a variety of applications.

(1) Length: 200 mm	Blade width: 10 mm	6.3 mm angle
(2) Length: 300 mm	Blade width: 15 mm	9.5 mm angle
(3) Length: 450 mm	Blade width: 20 mm	11 mm angle
(4) Length: 600 mm	Blade width: 20 mm	11 mm angle

Battery Servicing/Air Instruments

Battery Charger with Sulfation Recovery Function
KF-15-P2020EV2

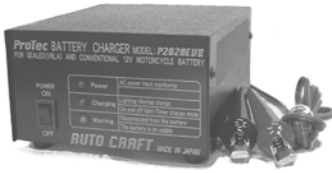

Applicable batteries	Capacity (Ah/10HR)	2.3 to 32
AC input	Voltage (V)	100
	Current (A)	0.4
DC output	Voltage (V)	20/15
	Current (A)	2
Size (W x D x H)	145 x 176 x 80	
Weight (approx. kg)	1.5	

● Dedicated 12 V charger

Analog Battery Tester
KF-15-ABTM30



- Easy-to-view analog meter adopted.
- Battery capacity selected from 6 stages.
- Accurate diagnosis possible by discharging 30A current.
- Easy operation simply by pressing TEST switch for 3 seconds.
- Judgment performed with color indicating meter needle.
- Displays open voltage when connected.
- Dedicated 12 V tester

Battery Charger with Sulfation Recovery Trickle Function
KF-15-P2020EV3

Applicable capacity (Ah/10HR)	AC input		DC input		Size (WxDxH)	Weight (approx. kg)
	Voltage (V)	Current (A)	Voltage (V)	Current (A)		
2.3~32	100	0.4	20/15	0.2/2	110x160x83	1.5



- Recovery → normal → sustained charging with this single charger.
- Battery degradation is prevented by maintaining a fully charged state.
- Degraded battery electrodes are restored with a special mode during initial charging.
- Dedicated 12 V charger

Compact Battery Charger for Motorcycles, etc.
KF-15-XS08JP



Output current: 0.8A

For motorcycles, and compact marine and farming machinery
Charging is possible with the battery mounted, and without having to remove the minus terminal.

Charger for Lithium Ferrite Battery
KF-15-MXS50JPL



Output current: 4.3A

Lithium ferrite battery (LiFePO4)
Performs appropriate charging with a dedicated algorithm.

Dropper for Battery Fluid
KF-18-BOS001



Can also be used for brake fluid.
Nozzle with transparent bottle to allow the fluid quantity drawn up to be verified.
Set of 2

Battery and Coolant Test Scope
KFX-9-235



With a sample containing as little as 2 to 3 drops of liquid, this measuring instrument can be used to easily measure antifreeze freezing limit temperature and concentration, measure the specific gravity of battery fluid, and judge the charge status.

Battery Syringe
KF-18-2



Ideal for sampling and replenishment of battery fluid and brake fluid.

Battery Density Gauge (Small)
KF-17-1



This tool has been certified.
Size: 270 mm

Air Instruments

Compressor



Package type

Model	KG-1-NLP15P	KG-1-NLP22P	KG-1-NLP37P
Power supply	Three-phase 200 V		
Output (kW)	1.5	2.2	3.7
Air tank capacity (L)	13.8	13.8	13.8
External size (mm)	825 x 710 x 1090	825 x 710 x 1090	825 x 710 x 1090
Weight (kg)	157	175	259
Noise level (dB)	51	53	56

Package type (built-in dryer)

Model	KG-1-NLP37PRD	KG-1-NLP55PRD
Power supply	Three-phase 200 V	
Output (kW)	3.7	5.5
Air tank capacity (L)	13.8	30
External size (mm)	885 x 710 x 1,285	1,005 x 930 x 1,645
Weight (kg)	292	384
Noise level (dB)	56	57

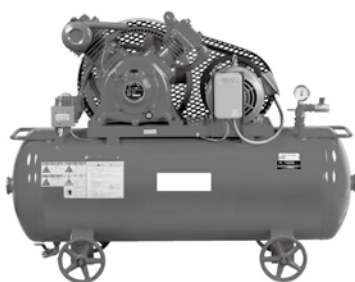

Reciprocating type

Model	KG-1-FS15P	KG-1-FS22P	KG-1-FS37P
Power supply	Three-phase 200 V		
Output (kW)	1.5	2.2	3.7
Air tank capacity (L)	83	99	130
External size (mm)	1035 x 485 x 835	1200 x 485 x 855	1240 x 530 x 960
Weight (kg)	122	155	259
Noise level (dB)	0.95MPa		

Sub Tank



Model	KG-1-PST57L	KG-1-PST83L	KG-1-PST150HL
Connection port diameter	Rc 1/2	Rc 1/2	Rc 3/4
Tank diameter (mm)	57	83	150
Height (mm)	1,090 x φ 370	1,150 x φ 415	1,460 x φ 465
Tank capacity (L)	36	55	100
Max. usage pressure (MPa)	0.99		1.47

Air Instruments

Air Trap (Water Remover) KG-2-10

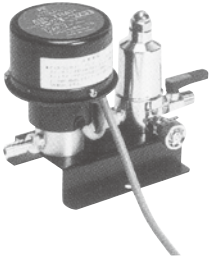

Compressor automatic water remover
Specify the compressor power supply voltage.

Compressor Oil 1 L KG-1-40 Compressor Oil 4 L KG-1-41



Replacement is required every six months.

Battery Air Reel (with Coupler) KGK-4-13A



- Pipe side connection: R1/4
- Normal pressure: 1.4MPa
- Hose: Outer diameter ϕ 10, inner diameter ϕ 6.4 mm
- Hose length: 10 m
- Weight: 3.1 kg
- Size: 330 (W) x 300 (D) x 111 (H) mm

Genuine Hose for Battery Air Reel KGK-4-2J95



- Normal pressure: 1.4MPa
- Hose: Outer diameter ϕ 10, inner diameter ϕ 6.4 mm
- Hose length: 10 m

Hi-coupler

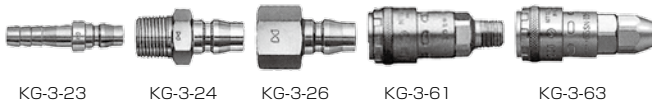

For hose (plug)	KG-3-23
1/4 male screw (plug)	KG-3-24
Hollow screw (plug)	KG-3-26
1/4 male screw (socket)	KG-3-61
For urethane hose (socket)	KG-3-63

Nitrogen Generator KF-15-HP1370

High-purity nitrogen gas is created by employing the PSA system.

Compatible vehicles	Light motor cars to compact trucks
Nitrogen generator method	Oxygen and nitrogen are separated using a PSA system active carbon adsorbent.
Nitrogen gas purity	95 to 99%
Nitrogen gas generation qty	50 ℓ /min. (3000 ℓ)
Built-in tank	39 ℓ (equivalent to 0.8MPa 312 ℓ) Automatic filling is performed at tank internal pressure of 0.8MPa or lower
Air pressure (input side)	1.0MPa
Nitrogen pressure (output side)	0.8MPa
Tire vacuum draw	3000 ℓ /h
Power supply	100 VAC, 50/60Hz
Washing hose	3/8 15 m
Exterior size (W x D x H mm)	720 x 425 x 1120
Weight (kg)	74



Duster Coupler for Urethane Hose KG-3-DCS65

A coupler, duster, and swivel in one tool. Duster work can be performed without disconnecting the tool.



- Duster work possible with too connected for improved workability.
- Hose twisting eliminated and reduced load on hands with ball bearing type swivel mechanism.

Auto Lock Swing Coupler for Urethane Hose KG-3-TSRL65SN

Newly shaped air coupler!



- Lock is automatically applied to sleeve part by inserting air tool for 6.5 x 10 urethane hose and swinging. When disconnecting, air is released from the hole at the end, eliminating the recoil and sound caused by residual pressure.

Rotary Plug KG-3-RL20PM

360 swing rotation with newly developed rotary function. Significantly improved air tool workability!

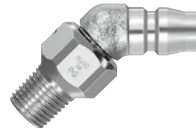

- Hose connection swing plug for air tools, instruments.
- Attached to unit at 45° angle, eliminating annoying loads from the hose.
- For connection of air tools such as ?Tucker Naylor? impact wrench.
- Male screw 1/4

Penguin Air Duster Gun KG-5-5



Coupler sold separately

- Lightweight, compact design for easy handling.
- Ergonomic design that fits in your hand.
- Easy-to-grip large lever for easy flow adjustment also.
- Safety nozzle that does not rebound even if nozzle tip covered.

Increase Air Duster KG-5-EA123AM



Coupler sold separately

- Great for draining water after washing and when large-capacity air blow is required.

Brushing Blow Gun (Horsehair) KG-5-KBBDB



- Revolutionary air gun capable of simultaneous brushing and air blow.

Brushing Blow Gun (Nylon) KG-5-KBBDW



- A soft horsehair and hard nylon type are available, with the most appropriate type selected based on the location.

Caterpillar Slide Duster Gun KG-5-KCPD



Duster gun

- High air discharge volume with straight body with no bends.

Pneumatic/Power Tools

Cordless Impact Wrench 1/2SQ

KH-3-SI165W



Tightening capability, high-strength bolts:
M8 to M14
Standard bolts: M10 to M16
Max. torque: 350 N·m
Insertion angle: 1/2SQ
Charging time: Approx. 20 to 25 min.
Rotation speed: 0 to 1,700 min⁻¹
Weight: 1.65 kg (incl. battery)
Noise level: 95.9/(106.9) dBA
Vibration value: 15.7 m/s²
Standard accessories: Dedicated charger, battery pack × 2, carrying case

Cordless Impact Wrench

KI-1-41581
KI-1-41582 With 2 Batteries

Improved life with use of Li-ion battery!



Insertion angle: 1/2SQ
Capability: Max. torque 451 N·m
Weight: 2.1 kg

Rechargeable Pen Impact Driver

KI-10-TD020DS



With its slim body, it can be used with ease in even the tightest spaces.

Lightweight: 0.53 kg
Total length: 213/276 mm
(when folded/when straight)

KOWA Silent Air Ratchet Wrench

KHK-2-1208Q



Silent type in consideration of environment
With air regulator
Insertion angle: 3/8SQ

Pocket Air Ratchet Wrench 3/8SQ

KH-2-SI1108A

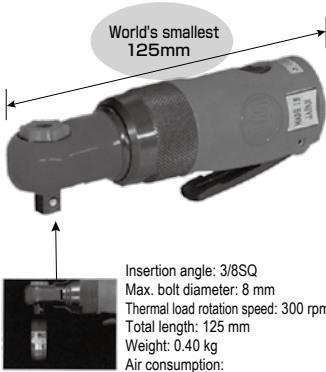

World's smallest
125mm

Insertion angle: 3/8SQ
Max. bolt diameter: 8 mm
Thermal load rotation speed: 300 rpm
Total length: 125 mm
Weight: 0.40 kg
Air consumption:
0.17 m³ (normal)/min.

Ultra-compact Air Ratchet Wrench

KH-2-SMR5S



Total length as small as your palm at 135 mm

Palm size

Insertion angle: 3/8SQ
Max. bolt diameter: 8 mm
Weight: 500 g
No-load rotation speed: 240 rpm
Total length: 135 mm

Compact Impact Wrench

KHK-2-2040S

Excellent for use even in "tight spaces" such as when rotating clamp pulleys, or removing and installing engines!!

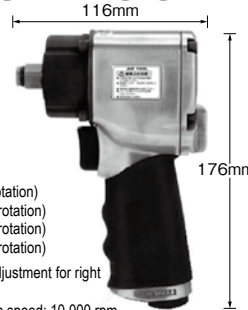

Torque:
710 N·m (left rotation)
678 N·m (right rotation)
488 N·m (right rotation)
271 N·m (right rotation)

With 3-stage adjustment for right rotation
No-load rotation speed: 10,000 rpm
Weight: 1.55 kg

Impact Wrench

KH-2-SA1482



Power: 583 N·m
Weight: 1.25 kg
Insertion angle: 1/2SQ
Max. bolt diameter: 13 mm
Weight: 1.25 kg
Rotation speed: 13500 rpm
Clutch: Twin hammer type

Lightweight High-power Impact Wrench 1/2SQ

KH-2-SI1600BULTRA

Shortest body in class, lightweight 1.04 kg, max. torque in class of 460 N·m



Comfortable fully-molded grip
Lighter, plastic body

Insertion angle: 1/2SQ
Max. bolt diameter: 16 mm
Max. torque: 460 N·m
Total length: 148 mm
Weight: 1.04 kg
Hammer method: Twin hammer

Impact Wrench 1/2SQ

KH-2-SI1490ULTRA

Strong plastic body and comfortable fully-molded grip



Insertion angle: 1/2SQ
Max. bolt diameter: 18 mm
Max. torque: 850 N·m
Total length: 175 mm
Weight: 1.76 kg
Hammer method: Twin hammer

Belt Sander

KH-3-SI2700



With belt replacement stopper
Belt size: 10/12 mm × 330 mm
Rotation speed: 16,000 rpm
Belt speed: 1,100 m/min.
Total length: 275 mm
Weight: 0.8 kg
Air consumption: 0.2 m³ (normal)/min.

Scratch Belts

KH-3-SI2700SKB

Attach to belt sander
Size: 10 × 330 mm
Qty: 10



Air Saw

KH-4-SI4710



File attachment shaft diameter: φ5 mm
No-load rotation speed: 10,000 srm
Stroke: 10 mm
Total length: 215 mm
Weight: 0.8 kg
Air consumption: 0.08 m³/min.

Forward and Reverse Rotation Air Drill

KH-5-SI5506



Ultralight!

Drilling ability: 10 mm
No-load rotation speed: 1,300 to 2,250 rpm
Total length: 115 mm
Weight: 0.59 kg
Air consumption: 0.21 m³ (normal)/min.

Cordless Polisher

KH-3-SI410E



Rotation speed: 0 to 2,200 min⁻¹
Pad diameter: φ73 mm
Size: 130 × 230 mm
Weight: 0.88 kg

Electric Gear Action Polisher

KH-3-SI510EGA

Eliminates buff traces.

With this gear action type, buff traces when polishing are rare, and any traces can be easily eliminated.



Accessories: φ165 wool buff
φ165 urethane buff, 1 of each

Electrical Equipment/Measuring Instruments

Lamp Reel with LED Work Light

KL-29-HLED10R

With LED work light (7W)
Specification: with VCT-1.25 x 3-core socket
Cable length: 10 m
Rating: 125 V, 6A
With overheating prevention thermo switch
This is provided as a set together with evolution light (KF-33-HLED20).



Socket Reel

KL-29-HUC910C

Specification: with VCT-1.25 x 3-core socket
Cable length: 10 m
Rating: 125 V, 6A
With overheating prevention thermo switch



Remote Controller Reel

KL-29-HCP804

Specification: VCT-1.25 x 4-cores
Cable length: 8 m
Rating: 30 V, 6A
With overheating prevention thermo switch



* Does not include pendant switch.

Evolution Light

KL-33-HLED20

Rechargeable LED work light capable of connection to cable reel
Powerful brightness of 500 lm + superwide angle LEDs

Battery: Li-ion polymer, 7.4 V
Lighting time: Hi 3 hours, Low 8 hours
Charging time: Approx. 4 hours
Input power supply: 100 V
Size: 345 x 42 x 27 mm, 270 g



Equipped with a high-performance Li-ion battery, this light provides approximately 3 hours of lighting in the stunningly bright Hi mode. Using the cable with lock provided, use and charging are both possible while connected to your cable reel. Comes with dedicated cable that also allows charging from a 100 V socket. Equipped with convenient hook and magnet.

Rechargeable Strong Light 8W

KL-29-LB8A

KL-29-LB8AE With Chemical-resistant Cover

Slim shape ensures effortless lighting in small spaces.
Continuous lighting is possible for 2 hours on a single charge (approx. 3 hours).
The charger is equipped with a charging safety control circuit to prevent overcharging. Equipped with drop prevention strap.

Total length: 450 mm
Weight: 350 g (incl. battery)
1/3 the weight of the previous model.
The LB-8E comes with a chemical-resistant cover.



* 13W spec. model also available.

Captain LED Light (LED Unit)

KL-29-LED18

Dedicated Captain Light LED replacement unit

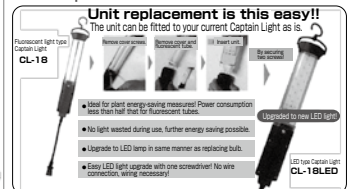

Unit replacement is this easy!!

The unit can be fitted to your current Captain Light as is.

Useful for plant energy saving measures! Power consumption less than half that for fluorescent tubes.

No light wasted during use, further energy saving possible.

Upgrade to LED lamp in same manner as replacing bulb.

Easy LED light upgrade with one screwdriver! No wire connection, wiring necessary!

LED for Captain Light CL-18LED

High-color LED Strong Light (100 VAC)

KL-29-SLLED20WRa

Ideal for paint and gloss check work.

100 VAC type

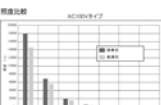
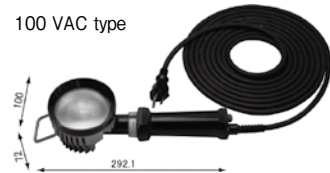

LED: 20W
Color rendering index: Ra95
Color temperature: 5000 K
Total luminous flux: 1240 lm
Cable length: 5 m
Weight: 1.1 kg

High-color LED Strong Light (Cordless)

KL-29-LBLED6WRa

Ideal for paint and gloss check work.

Cordless type

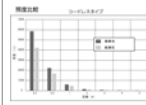
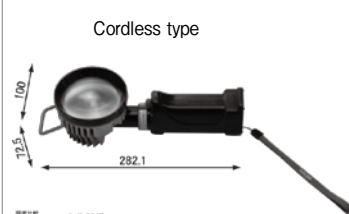

LED: 6W
Color rendering index: Ra95
Color temperature: 5000 K
Total luminous flux: 320 lm
Continuous usage time: 2.5 hours
Weight: 660g

Rechargeable LED Hand Lamp

KL-33-245LED

Bright! 24 LEDs

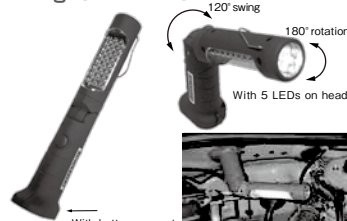

Specifications
• Battery: Li-ion, 3.7 V
• Charging time: Approx. 4 hours
• Continuous lighting: Approx. 7 hours

Size
• 50 x 70 x 285 mm
Weight
• 0.28 kg

High-power LED Light

KL-33-MAGSY

Shock-resistant, lights up the dark with approx. 70 LEDs



Size: 41 x 57 x 4158 mm (body only)
Waterproof function: IP66 compliant
Total luminous flux: 380 lm
Continuous usage time: 3.5 hours
Charging time: Approx. 3.5 hours
Weight: 350 g

Measuring Instruments

Torque Wrench 40 to 140 N·m

KK-18-10

Torque Wrench 10 to 45 N·m

KK-18-14



Measurement range: 40 to 140 N·m Angle drive: 1/2SQ
1 graduation on scale: 1 N·m Weight: Approx. 0.85 kg
Measurement range: 10 to 45 N·m Angle drive: 3/8SQ
1 graduation on scale: 0.5 N·m Weight: Approx. 0.45 kg

Torque Wrench 21 to 105 N·m

KK-18-20

Torque Wrench 28 to 210 N·m

KK-18-21



Measurement range: 21 to 105 N·m Angle drive: 3/8SQ
Measurement range: 28 to 210 N·m Angle drive: 1/2SQ

(Low cost type)

Torque Wrench for Motor Sports 10 to 70 N·m

KK-18-MTQL70N



Torque adjustment range: 10 to 70 N·m
1 graduation on scale: 1 N·m
Total length: 283 mm Angle drive 3/8SQ
Weight: Approx. 0.47 kg

Torque Wrench for Motor Sports 20 to 140 N·m

KK-18-MTQL140N



Torque adjustment range: 20 to 140 N·m
1 graduation on scale: 1 N·m
Total length: 390 mm Angle drive: 1/2SQ
Weight: Approx. 0.77 kg

Measuring Instruments

Digital Torque Wrench 1/2SQ KK-18-DG4



Compatible with both right/left screw directions
Measurement accuracy: ± 2.5 to 3.5%
Measurement range: 6.8 to 135 N·m
Total length: 445 mm
Weight: 1.8 kg

PITA Micrometer Caliper 200 mm KK-2-PITA



The end face of the caliper has been cut. These revolutionary new calipers have a flat head.

Dial Calipers KK-2-DVC15



These calipers have a built-in dial, and measurement values can be read directly from the dial without a vernier.
● Max. measurement length: 150 mm
Min. reading 0.02 mm Single needle rotation: 2 mm

Digital Calipers KK-2-D150

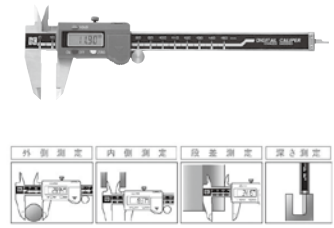

Easy-to-view, immediate measurement with digital display, equipped with hold function.
● Max. measurement length: 150 mm
Min. reading: 0.01 mm

Dial Gauge KK-14-1



Measurement range: 0 to 10 mm
Minute scale: 1/100 mm
Size: 52.5 mm

Magnet Stand KK-13-1



Dial gauge stand
Total length: 233 mm
Weight: 1.5 kg
Model: BA-1

Surface Plate

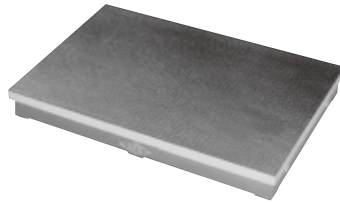

Part No.	Size (mm)	Weight (kg)
KK-15-1	300 × 300 × 50	13
KK-15-3	400 × 400 × 75	28
KK-15-4	500 × 500 × 75	39
KK-15-5	750 × 750 × 125	135

V Block A Type 150 mm KK-16-4

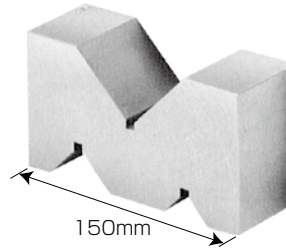

Required for measurement of the bends of crank shafts and cam shafts, etc.
Weight: 8 kg

Thickness Gauge KK-8-4



Part No.	Quantity	Size (Length × width mm)	Measurement range
KK-8-1	25	65 × 12.7	0.03 to 1.0
KK-8-2	9	70 × 12.7	0.04, 0.05, 0.06, 0.07, 0.08, 0.1, 0.15, 0.2, 0.3
KK-8-3	13	80 × 12.7	0.04, 0.05, 0.06, 0.07, 0.08, 0.1, 0.15, 0.2, 0.2, 0.30
KK-8-4	9	100 × 12.7	0.04, 0.05, 0.06, 0.07, 0.08, 0.1, 0.15, 0.2, 0.3
KK-8-5	9	150 × 12.7	0.04, 0.05, 0.06, 0.07, 0.08, 0.1, 0.15, 0.2, 0.3
KK-8-6	9	230 × 12.7	0.04, 0.05, 0.06, 0.07, 0.08, 0.1, 0.15, 0.2, 0.3
KK-8-7	9	300 × 12.7	0.04, 0.05, 0.06, 0.07, 0.08, 0.1, 0.15, 0.2, 0.3

Digital Mini Depth Gauge KF-14-DMD25

Ideal for measurement of tire groove and brake pad thickness, etc.



Easy measurement with digital display, equipped with hold function, lightweight plastic body
Measurement range: 0 to 25 mm
Min. reading: 0.1 mm
Power supply: SR44 button battery x 1
Total length: 112.5 mm
Weight: 40 g

Dial Mechanic Gauge KF-14-4



Lightweight and thin, with one-touch friction pointer for accurate measurement.
The double scales are each in a different color.
· Outer scale: Disc pad thickness
· Inner scale: Tire dip depth
· Scale: 0.1 mm
· Disc pad outer scale: 2 to 12 mm
· Disc pad inner scale: 0 to 10 mm

Super Check Set of 6 KK-19-1



Used to discover engine block cracks and gasoline leaks.
Use in the order,
penetrant → developing fluid
application → cleaning solution.

External Micrometer KK-1-2



Measurement range: 20 to 50 mm
Min. scale: 1/100 mm

Thermometer with Laser Pointer KK-17-MT7



Temperature measurement of engines, mufflers, manifolds, radiators, brakes, and tires is performed in one second. Speed measurement
Equipped with a laser pointer for highlighting measurement locations.

Measurement range:
-50 to 400 °C

Front Fork Bend Measuring Instrument 2K-K-01



Bends can be further verified digitally without disassembling the front forks, allowing the user to judge whether the forks can be reused, or whether repair is required.
Ideal for diagnosis of damaged vehicles and assessing trade-in value.

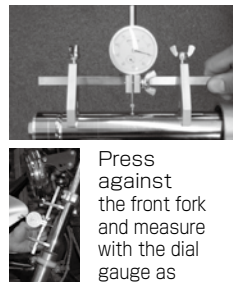

Press against the front fork and measure with the dial gauge as shown on the right.

* Dial gauge sold separately.

Standard Cylinder Gauge

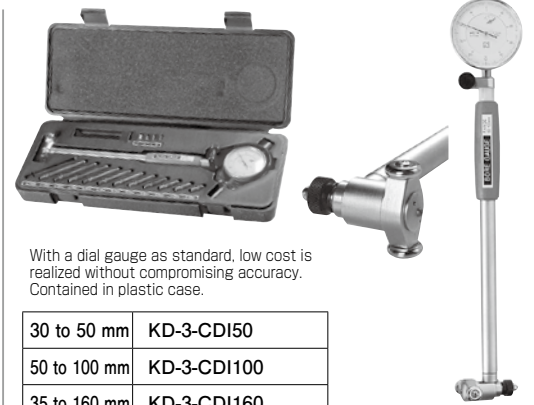

With a dial gauge as standard, low cost is realized without compromising accuracy. Contained in plastic case.

30 to 50 mm	KD-3-CDI50
50 to 100 mm	KD-3-CDI100
35 to 160 mm	KD-3-CDI160

KOWA Tool Caddy (Truster) Series

Truster D

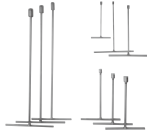
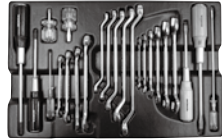
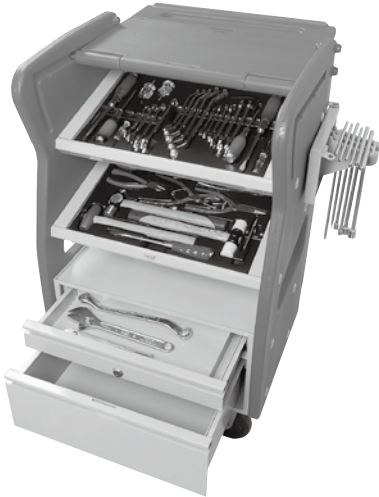

Part no.	Product name
KLK-27-151	Truster D + Tool Set

Set contents	
Double-ended spanners	6x7,8x9,10x12,12x14,14x17,17x19mm
Combination spanners	10,12,14,17mm
45° offset wrenches	8x9,10x12,12x14,14x17,17x19mm
T-type box wrenches	8,9,10,12,14,17mm
T-type long box wrenches with ball	10,12,14mm
L-type wrench	10mm
Snap ring pliers	Open, close
Combination pliers	200mm
Wooden handled penetration screwdrivers	(-)100,150mm (+)No.2,No.3
Wiring screwdrivers	(-)200mm (+)No.00
Stubby screwdrivers	(-)(+)
T-type screwdrivers	(-)No.3 (+)No.2,No.3
Heavy-duty screwdriver	(-)150mm
Plastic hammer	1Lb
Hand hammer	1Lb
Copper hammer	1Lb
Thickness gauge	100mm
Nippers	150mm
Radio pliers	150mm
Tool caddy (Truster D type)	650 (W) × 510 (L) × 965 (H) mm

Part no.	Product name
KLK-27-102	Truster D Type Tool Caddy only
KLK-00-05	Tool Set only

Truster A



Part no.	Product name
KLK-27-08AN	Truster A + Tool Set

Set contents	
Double-ended spanners	6x7,8x9,10x12,12x14,14x17,17x19mm
Combination spanners	10,12,14,17mm
45° offset wrenches	8x9,10x12,12x14,14x17,17x19mm
T-type box wrenches	8,9,10,12,14,17mm
L-type wrench	10mm
Snap ring pliers	Open, close
Combination pliers	200mm
Wooden handled penetration screwdrivers	(-)100,150mm (+)No.2,No.3
Wiring screwdrivers	(-)200mm (+)No.00
Stubby screwdrivers	(-)(+)
T-type screwdrivers	(-)No.3 (+)No.2,No.3
Heavy-duty screwdriver	(-)150mm
Plastic hammer	1Lb
Hand hammer	1Lb
Copper hammer	1Lb
Thickness gauge	100mm
Nippers	150mm
Radio pliers	150mm
Flat power socket wrench set 3/8SQ	See page 23 of catalog
Flat chisel	13x160mm
Water pump pliers	250mm
Assorted files	Set of 5
Air gun, high coupler	AG-50L·20PFF
Monkey wrench	300mm
Center punch	125mm
Tool caddy (Truster A type)	650 (W) × 510 (L) × 965 (H) mm

Part no.	Product name
KLK-27-8AN	Truster A Type Tool Caddy only
KLK-00-8K	Tool Set only

Roller Cabinet 5 Level KL-27-GT0006



Specifications:

Caddy size: 680 (W)×460 (D)×810 (H) mm
 Weight: 52.0 kg
 Drawer sizes:
 Upper 3 drawers: 580 (W)×406 (D)×75 (H) mm
 Lower 2 drawers: 580 (W)×406 (D)×306 (H) mm

Roller Cabinet 7 Level KL-27-GT0003



Specifications:

Caddy size: 680 (W)×460 (D)×960 (H) mm
 Weight: 64.0 kg
 Drawer sizes:
 Upper 5 drawers: 580 (W)×406 (D)×75 (H) mm
 Lower 2 drawers: 580 (W)×406 (D)×150 (H) mm

Hand Tools

Handy Tool Box



Part no.	Product name
KLK-27-602	Handy Tool Box + Tool Set
Set contents	
Combination spanners	10,12,14,17mm
45° offset wrenches	8x10,10x12,11x13,12x14,14x17,17x19,21x23mm
T-type box wrenches	8,9,10,12,14,17mm
Combination pliers	200mm
Wooden handled penetration screwdrivers	(-) 100 (+) No.2
Thickness gauge	100mm
Nippers	150mm
Sockets 3/8SQ	6,7,8,9,10,12,13,14,17,19,21,22,23,24mm
Conversion sockets	凸1/2,凹3/8
Deep sockets	10,12,14,17mm
Extension bars	100,150mm
T-handle	250mm
Ratchet handle	200mm
Universal joint	3/8SQ
Tool box (Handy type)	555 (W) × 240 (L) × 220 (H) mm
Part no.	Product name
KL-27-Y983020	Handy Tool Box only
KLK-27-60T	Tool Set only

Tool Kit

● Hand-picked set in spacious box.



■ 110 item tool kit

Insertion angle
9.5mm

Insertion angle
6.35mm

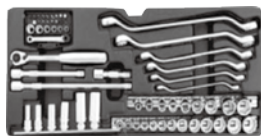

Socket	8-10-12-13-14-17-19-21-22mm
Deep sockets	8-10-12-14-17-19mm
Ratchet handle (lightweight Super Ten Light)	203mm
Extension bars	75-150-250mm
Universal joint	
Offset wrenches	8x10-10x12-11x13-14x17-19x21-22x24mm
Combination wrenches	10-12-13-14-17mm
Pliers	200mm
Monkey wrench	250mm
Heavy-duty nippers	150mm
Radio pliers	150mm
Screwdrivers	● 5mm×75- ● 6mm×100- ● 8mm×150
Screwdrivers	⊕ No.1×75- ⊕ No.2×100- ⊕ No.3×150
Stubby screwdriver	● 6mm
Stubby screwdriver	⊕ No.2
Socket hanger unit	275mm
Socket hanger unit	220mm
Penetration type magnetic socket insert	
Mini reverse gear & spline socket set	
Spline socket hanger set	6-8-10-11-12-13-14-16-17-18-19-21-22mm
One-pound hand-hammer	
9-piece ballpoint key wrench set	1.5-2-2.5-3-4-5-6-8-10mm
7-piece mini ratchet & driver bit set	
Round magnetic tray	φ150×41mm
Bearing type three-drawer tool box	557×245×275mm

Part no.	Product name
KL-27-DKS9110R	Tool Kit (red)
KL-27-DKS9110B	Tool Set (black)

Mirror Finish Hand Tools (NT Series)

Original names laser-etched into highest grade mirror-finish tools.

Fit crafted by seasoned pros of 50-odd years

Tool owner's name laser-etched on one side

Laser-etching sample

KOWA SEIKI
Original name etched

NT Series double-ended spanner set
KLK-1-SRKS

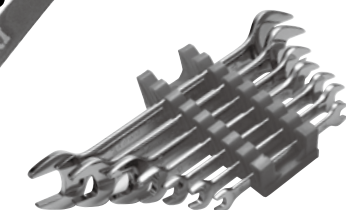

Sizes
6×7, 8×9, 8×10, 10×12, 12×14, 14×17, 17×19mm

NT Series offset wrench set
KLK-3-MRKS

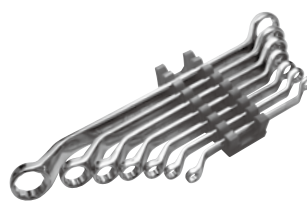

Sizes
8×9, 8×10, 10×12, 12×14, 14×17, 17×19, 22×24mm

NT Series combination spanner set
KLK-1-KRKS

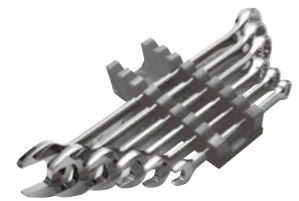

Sizes
8, 10, 12, 14, 17, 19mm

High-precision required of bolts, nuts

* The size and number of characters is limited.

Insulator Tools

Insulator Tool

Recent years have seen rapid adoption of environmentally-friendly vehicles such as HEVs (hybrid vehicles) and FCVs (fuel cell vehicles) in response to environmental issues. Until now, however, there have been only "thick, large" work tools guaranteeing insulation for live wire work involved in maintenance and service. In other words, there have been no insulated tools ideal for work in tight spaces, and that can be used efficiently in automobile service workshops. In response to this, we have developed the "Kowa Insulator Tool" series of insulator tools for automobile maintenance. These are the same as the insulator tools with "EN60900 (European unified specification)" designed to prevent "shorting and electric shocks" when carrying out maintenance work on HEVs and FCVs, etc.

Insulator Tool Handy Set 2 A Type KLIN-27-SELA

Insulator Tool Handy Set 2 B Type KLIN-27-SELB



Set contents

- T-handle
- Sockets: 8, 10, 12 mm
- Long socket: 10 mm
- Extension bars: 50, 100 mm
- Screwdrivers: Minus 75, plus No. 2
- Pick-up tool
- Insulated gloves
- Voltage tester
- Torque wrench (B type only)
- Insulated cover (B type only)

Insulator Tool Handy Full Set KLIN-27-FULL

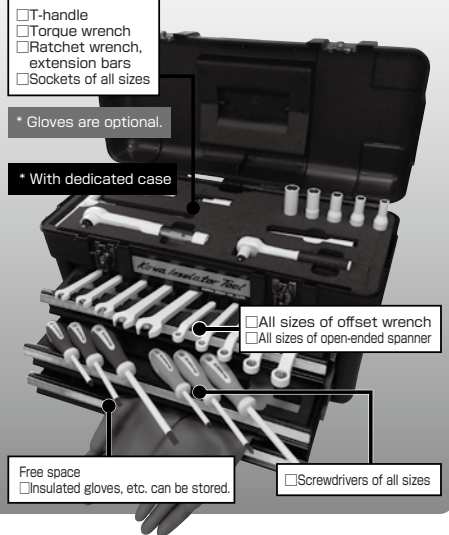

Set contents

- Insulated open-ended spanners: 7, 8, 10, 12, 14 mm
- Insulated offset wrenches: 7, 8, 10, 12, 14 mm
- Insulated T-handle 3/8SQ
- Insulated torque wrench 3/8SQ: 5 to 25 N·m
- Insulated ratchet handle 3/8SQ
- Insulated socket wrenches: 7, 8, 10, 12, 14 mm
- Insulated extension bars: 50, 100 mm
- Insulated screwdrivers: Plus No. 1, 2, 3 Minus 75, 100, 150
- Insulated long socket: 10 mm
- Insulated gloves



KLIN-2-285EN
Insulated T-handle
3/8SQ



KLIN-2-KWRH311
Insulated ratchet handle
3/8SQ



KLIN-2-(7 to 14)EN
Insulated socket wrenches
7 to 14 mm



KLIN-2-50(100)EN
Insulated extension bars
50, 100 mm



KKIN-2-PQL25EN
Insulated torque wrench 3/8SQ
Torque adjustment range: 5 to 25 N·m



KKIN-18-N50LTDK
Insulated torque screwdriver



KLIN-16-9(10)(11)
Insulated screwdriver (plus)



KLIN-16-2(3)(5)
Insulated screwdriver (minus)



KLIN-1-(7 to 14)
Insulated open-ended spanners
7 to 14 mm



KLIN-3-(8 to 14)
Insulated offset wrenches
7 to 14 mm



4K-P-22
Insulated gloves



4K-P-31
Insulated gloves (thin type)



KLIN-36-3
Pick-up tool
* Used to pick up
dropped bolts, etc.



KE-32-SK6592
Voltage tester
400/600 VAC
600 VDC



4K-P-50
Insulated cover
600 × 1,000 mm

⚠ WARNING

Those responsible for carrying out motorcycle maintenance must ensure a sufficient understanding of information (service manuals, etc.) provided by the motorcycle manufacturer, and possess the qualifications required to carry out motorcycle maintenance work. Injuries may result if work is carried out without sufficient knowledge. It may be necessary to take lectures in special education or obtain qualifications as stipulated by law to carry out high-voltage work. These products should only be used by those meeting these conditions. Electric shock or injuries may result if work is carried out without sufficient knowledge. Use for parts of voltage 750 VDC or lower. These products can only be used for parts of 1,000 VAC or 1,500 VDC or lower. If using a voltage greater than 750 VDC, there is a possibility of electric shock if tools are not insulated. Use tools only in combination with products in the Insulator Tool series. If using tools in combination with those of other companies, or with those in another tool series, there will be no insulation, and electric shocks may occur. If the recommended period of use (3 years from date of purchase) is exceeded, please discontinue use of these products. For example, even if there are no scratches on the surface of the product, insulation will be lost due to material degradation, and electric shocks may occur. If you wish to continue use of the products, please contact your local Kowa Seiki office. There may be cases where the recommended period of use is extended following reinspection (fee applicable). However, the respective manufacturers should be contacted with inquiries relating to insulated gloves.

⚠ Warning: Indicates content that may result in death or serious injury if products are handled incorrectly.

Hand Tools (KOWA STREAMLINE)

Spanner Set

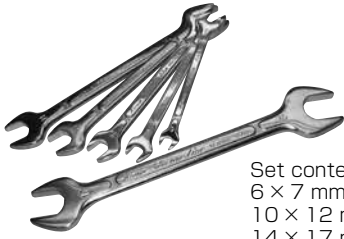

Set contents: Set of 6
6 × 7 mm, 8 × 9 mm
10 × 12 mm, 12 × 14 mm
14 × 17 mm, 17 × 19 mm

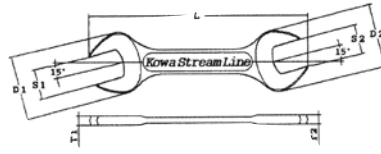

Part No.	Part Name
KLK-1-010	Set of 6 spanners

(Sold individually)

Part No.	Size		D1	D2	T1	T2	L	Weight (g)
	S1	S2						
KLK-1-21	6	7	13.5	15.5	2.7	2.7	107	15
KLK-1-24	8	9	17.5	19.5	3.7	3.7	125	31
KLK-1-26	10	12	21.5	26	5	5	145	57
KLK-1-28	11	13	23.5	28	5.5	5.5	155	65
KLK-1-29	12	14	26	30	6	6	165	91
KLK-1-30	14	17	30	36	6.5	6.5	190	125
KLK-1-31	17	19	36	40	7	7	210	165

Combination Wrench Set

Set contents: Set of 5
8, 10, 12, 14, 17 mm

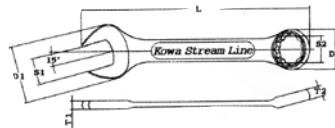
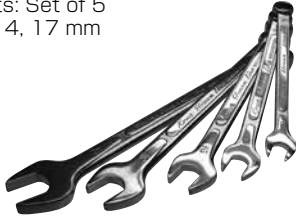

Part No.	Part Name
KLK-1-015	Set of 5 combination wrenches

(Sold individually)

Part No.	Size		D1	D2	T1	T2	L	Weight (g)
	S1	S2						
KLK-1-79C	8	8	18	13	4	4	115	30
KLK-1-80	10	10	21.5	15.5	4.5	4.5	131	41
KLK-1-81	12	12	26.5	18.5	5.5	5.5	155	72
KLK-1-82	14	14	30	21	6.5	6.5	180	102
KLK-1-83	17	17	36	24.5	7	7	210	142

45° Offset Wrench Set

Set contents: Set of 6
8 × 9 mm, 8 × 10 mm
10 × 12 mm, 12 × 14 mm
14 × 17 mm, 17 × 19 mm

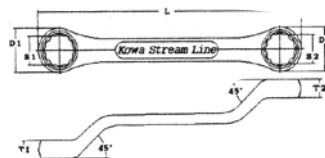

Part No.	Part Name
KLK-3-010	Set of 6 45° offset wrenches

(Sold individually)

Part No.	Size		D1	D2	T1	T2	L	Weight (g)
	S1	S2						
KLK-3-11	8	9	12	13.5	5.5	5.5	169	49
KLK-3-12	8	10	12.5	15.5	6.5	6.5	183	57
KLK-3-13	10	12	15.5	18.5	7.5	7.5	192	81
KLK-3-15	12	14	18.5	21	8.5	8.5	215	118
KLK-3-16	14	17	21	24.5	9.5	9.5	243	158
KLK-3-17	17	19	24.5	27	10	10	276	215

T-type Box Wrench Set

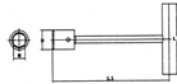

Set contents: Set of 5
8, 10, 12, 14, 17 mm

(Sold individually)

Part No.	Size	D1	L1	L2	Weight (g)
	S				
KL-4-19	7	11	248	100	100
KL-4-1	8	12	258	200	180
KL-4-2	9	14	188	100	120
KL-4-4	10	14.5	259	200	280
KL-4-5	11	16	259	200	270
KL-4-6	12	18	261	200	340
KL-4-7	13	18.5	261	200	340
KL-4-8	14	20	261	200	350
KL-4-9	17	24	273	200	510
KL-4-10	19	26.5	283	200	530
KL-4-11	21	29	296	250	850

Part No.	Part Name
KL-4-010	Set of 5 T-type box wrenches
KL-4-MG4S	Set of 4 T-type box wrenches with magnet

<With magnet>

Part No.	Size	D1	L1	L2	Weight (g)
	S				
KL-4-1MG	8	12	258	200	180
KL-4-4MG	10	14.5	259	200	280
KL-4-6MG	12	18	261	200	340
KL-4-8MG	14	20	261	200	350

Long Box Wrench with T-type Ball

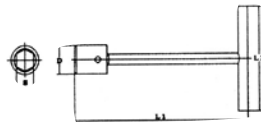

(Sold individually)

Part No.	Size	D	L1	L2	Weight (g)
	S				
KL-4-50	8	12	599	200	400
KL-4-45	10	14	599	200	400
KL-4-46	12	17	600	200	500
KL-4-47	14	20	600	250	550
KL-4-49	17	23	600	250	670
KL-4-55	19	25	600	250	680

<With magnet>

Part No.	Size	D	L1	L2	Weight (g)
	S				
KL-4-50MG	8	12	599	200	400
KL-4-45MG	10	14	599	200	400
KL-4-46MG	12	17	600	200	500
KL-4-47MG	14	20	600	250	550

T-type Hex Wrench Set KLK-60-01



Set contents (Set of 4)
4, 5, 6, 8 mm

T-handle 3/8SQ KLK-2-285

Size	Weight
350 mm	405 g

The 9.5 mm insertion angle means it can be used for sockets, etc.

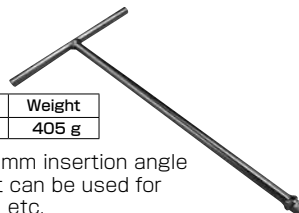

T-type Screwdrivers



Part No.	Size	D	L1	L2	Weight (g)
KL-16-92	⊖ No.3	8	258	200	184

Part No.	Size	D	L1	L2	Weight (g)
KL-16-94	⊕ No.1	5	255	130	58
KL-16-95	⊕ No.2	6.3	206	100	70
KL-16-96	⊕ No.3	8	308	180	184
KL-16-97	⊕ No.4	9	359	206	260

Hand Tools

Wooden Handled Penetration Screwdrivers

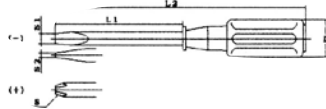

Part No.	Size		D	L1	L2	Weight (g)
	S1	S2				
KL-16-1	⊖ 4.5	0.6	25	50	153	69
KL-16-3	⊖ 6.0	0.8	28	100	218	117
KL-16-4	⊖ 7.0	0.9	33	125	258	183
KL-16-5	⊖ 8.0	1.0	33	150	283	217

Part No.	Size	D	L1	L2	Weight (g)
	S1				
KL-16-9	⊕ No.1	25	75	178	69
KL-16-10	⊕ No.2	28	100	218	117
KL-16-11	⊕ No.3	33	150	283	208
KL-16-12	⊕ No.4	33	200	355	333

Plastic-handled Screwdriver Set (Set of 5)

KLK-16-FSP



(Sold individually)

Part No.	Part Name
KLK-16-3P	Screwdriver (minus) No.2 (100 mm)
KLK-16-10P	Screwdriver (plus) No.2
KLK-16-11P	Screwdriver (plus) No.3
KLK-16-14P	Long-shaft long screwdriver (plus) No.2 (300 mm)
KLK-16-83	Mini stubby screwdriver (interchangeable plus/minus type)

Heavy-duty Penetration Screwdrivers

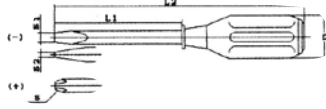

Part No.	Size		D	L1	L2	Weight (g)
	S1	S2				
KL-16-201	⊖ 5.5	0.7	27	75	183	84
KL-16-202	⊖ 6	0.8	30.5	100	223	118
KL-16-203	⊖ 8	1.0	34	150	295	210

Part No.	Size	D	L1	L2	Weight (g)
	S				
KL-16-205	⊕ No.1	27	75	183	87
KL-16-206	⊕ No.2	30.5	100	223	125
KL-16-207	⊕ No.3	34	150	295	208

Stubby Screwdrivers

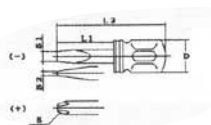
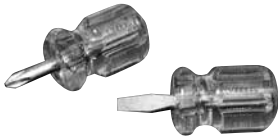

Part No.	Size		D	L1	L2	Weight (g)
	S1	S2				
KLK-16-81	6	0.8	31.5	25	72	53

Part No.	Size	D	L1	L2	Weight (g)
	S				
KLK-16-82	⊕ No.2	31.5	25	72	53

Wiring Screwdriver

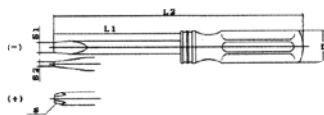
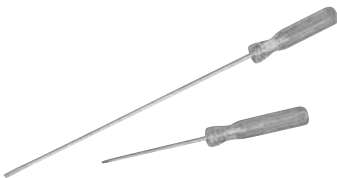

Part No.	Size		D	L1	L2	Weight (g)
	S1	S2				
KL-16-72	4	0.6	16	75	149	28
KL-16-73	4	0.6	16	100	174	30
KL-16-74	4	0.6	16	125	199	33
KL-16-75	4	0.6	16	150	224	37
KL-16-76	4	0.6	16	200	274	39

Part No.	Size	D	L1	L2	Weight (g)
	S				
KL-16-77	⊕ No.00	16	75	149	21
KL-16-78	⊕ No.0	16	75	149	26

Heavy-duty Screwdriver

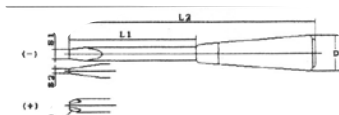

Part No.	Size		D	L1	L2	Weight (g)
	S1	S2				
KL-16-85	9	1.0	32	150	280	360

Part No.	Size	D	L1	L2	Weight (g)
	S				
KL-16-85A	⊕ No.3	32	150	280	360

Hand Tools

Combination Pliers



Part No.	Size	Total length	Weight (g)
KL-7-1	150	161	150
KLK-7-2	200	203	250

Water Pump Pliers KLK-7-10



Size	Total length	Weight (g)
250	253	320

Radius Pliers KLK-8-2



Size	Total length	Weight (g)
150	162	130

Heavy-duty Screw Pliers KL-7-ZA185



Used for removing stripped screws and rusted screws, as well as tightening.
Improved construction with non-slip special zigzag structure!
Total length: 185 mm

Extra-long Handled Pliers

Part No.	Part Name
KL-7-105M1113C	45°
KL-7-105M1113D	90°
KL-7-105M1114A	Straight



Great for holding down screws in recesses, pulling out wiring, and wrenching, etc.

Extra-long Handled Pliers

Part No.	Part Name
KL-7-105M1116A	18 mm ring
KL-7-105M1116B	14 mm ring
KL-7-105M1116C	8 mm ring



These are used to pull out and attach hoses and plug cables, and improve operability by tightly holding round, slippery parts.

Heavy-duty Nippers KLK-8-1



Size	Total length	Weight (g)
150	165	160

Booster Nippers KL-7-BN180



Easy cutting with lever mechanism
● Cutting capability: Piano wire ϕ 1.6, steel wire ϕ 2.6
● Total length: 180 mm

Snap Ring Pliers

Open (for Shafts)



Closed (for Holes)

Part No.	Size		Type	Total length	Weight (g)
	Min.	Max.			
KL-7-17	9	50	Open	204	152
KL-7-18	9	50	Closed	218	160

Heavy-duty Snap Ring Pliers

Open KLK-7-N17
Closed KLK-7-N18



Closed (for Holes) Open (for Shafts)

This is a new type with stronger tip.

Snap Ring Pliers 90° Bend KL-7-7011

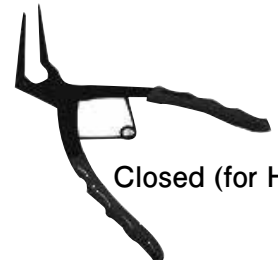

Closed (for Holes)

Great for inserting and removing snap rings for holes in deep places for brake callipers, master cylinder, front forks, etc.
● Tip length: 55 mm
● Total length: 170 mm

Hand Hammer



Part No.	Size	Total length		Weight (g)
		Min.	Max.	
KL-17-1	1/4 pound	282	180	
KL-17-2	1/2 pound	298	330	
KL-17-3	1 pound	325	542	
KL-17-4	1.5 pound	352	790	
KL-17-5	2 pound	385	1100	
KL-17-7	3 pound	410	1520	

Copper Hammer



Part No.	Size	Total length	Weight (g)
KL-17-30	1/2 pound	280	330
KL-17-31	1 pound	300	545
KL-17-32	1.5 pound	320	625
KL-17-33	2 pound	355	980

Plastic Hammer



Part No.	Size	Total length	Weight (g)
KL-17-50	1/2 pound	275	221
KL-17-51	1 pound	295	410
KL-17-52	1.5 pound	325	673
KL-17-53	2 pound	350	1080

Replacement head

Part No.	Size	Quantity	Weight (g)
KL-17-55	1/2 pound	1	13
KL-17-56	1 pound	1	28
KL-17-57	1.5 pound	1	47
KL-17-58	2 pound	1	78

Combination Hammer (Urethane/Metal) KL-17-ST10



Never lose your grip with this safe, shockless construction.

Hand Tools

Adjustable Wrench



Part No.	Size	Total length	Weight (g)
	Open max.		
KL-9-1	13	110	50
KL-9-2	20	159	115
KL-9-3	24	208	230
KL-9-4	29	268	400
KL-9-5	34	308	650
KL-9-6	44	385	1250
KL-9-7	53	465	1960

Pipe Wrench



Part No.	Nominal size	Pipe diameter	Total length (mm)	Weight (g)
KL-9-12A	150	15	148	200
KL-9-12	200	20	184	350
KL-9-13	250	25	247	650
KL-9-14	300	32	270	950

Flat Chisel

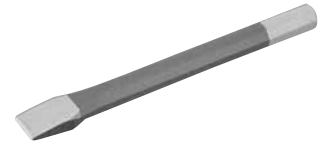

Part No.	Blade width	Total length	Weight (g)
KL-18-1	7	120	66
KL-18-2	10	140	75
KL-18-3	13	160	149
KL-18-4	16	175	172
KL-18-5	19	190	300
KL-18-6	22	200	400

Assorted Files

KL-19-46A



Size	Weight (g)
(Second cut) Flat	250
Half-round	
Round	
Square Triangular	

Center Punch



Part No.	Lightweight	Total length
KI-18-20	9	100
KI-18-21	11	125
KI-18-22	11	150

Auto Punch AP150

KL-18-AP150



Used for marking when drilling holes.
No hammer necessary

Spring Tool

KL-18-28R



Hammering with spring is possible in tight spaces, and long bolts can be loosened with ease. Especially useful for theft prevention screws used for main key and helmet holders.

Ratchet handle 1/4SQ

(1) Knurled grip type



(2) Polished grip type



(3) Rubber grip type



	Part No.	Width (mm)	Height (mm)	Total length (mm)	Weight (g)
(1)	KL-2-2753NB	22	18.7	115	90
(2)	KL-2-2753PB	22	18.7	115	87
(3)	KL-2-2753JB	22	18.7	115	77

Ratchet handle 3/8SQ

(1) Knurled grip type



(2) Polished grip type



(3) Rubber grip type



	Part No.	Width (mm)	Height (mm)	Total length (mm)	Weight (g)
(1)	KL-2-3753NB	30.5	26.4	200	320
(2)	KL-2-3753PB	30.5	26.4	200	286
(3)	KL-2-3753JB	30.5	26.4	200	260

Ratchet handle 1/2SQ

(1) Knurled grip type



(2) Polished grip type



(3) Rubber grip type



	Part No.	Width (mm)	Height (mm)	Total length (mm)	Weight (g)
(1)	KL-2-4750NB	38	35.9	250	548
(2)	KL-2-4750PB	38	35.9	250	553
(3)	KL-2-4750JB	38	35.9	250	508

Swing Ratchet Handle 1/4SQ

(1) Polished grip type



(2) Rubber grip type



	Part No.	Width (mm)	Height (mm)	Total length (mm)	Weight (g)
(1)	KL-2-2274PS	25	21.9	120	133
(2)	KL-2-2274JS	25	21.9	120	113

Hand Tools

Spinner Handle 1/4SQ

(1) Knurled grip type



(2) Polished grip type



(3) Rubber grip type



	Part No.	Width (mm)	Total length (mm)	Weight (g)
(1)	KL-2-2768N	14	130	86
(2)	KL-2-2768P	14	130	70
(3)	KL-2-2768J	14	130	73

Spinner Handle 3/8SQ

(1) Knurled grip type



(2) Polished grip type



(3) Rubber grip type



	Part No.	Width (mm)	Total length (mm)	Weight (g)
(1)	KL-2-3768N250	20.5	250	290
(2)	KL-2-3768P250	20.5	250	275
(3)	KL-2-3768J250	20.5	250	248

Spinner Handle 1/2SQ

(1) Knurled grip type



(2) Polished grip type



(3) Rubber grip type



	Part No.	Width (mm)	Total length (mm)	Weight (g)
(1)	KL-2-4768N300	28	300	600
(1)	KL-2-4768N380	28	380	696
(1)	KL-2-4768N450	28	450	784
(2)	KL-2-4768P380	28	380	665
(2)	KL-2-4768P450	28	450	748
(3)	KL-2-4768J380	28	380	600
(3)	KL-2-4768J450	28	450	690

Flat Power Socket Set 1/2SQ KLK-2-1A

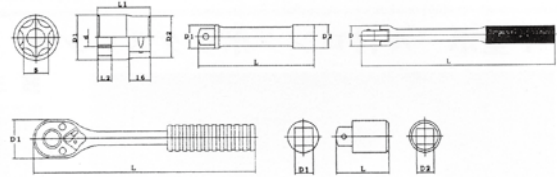
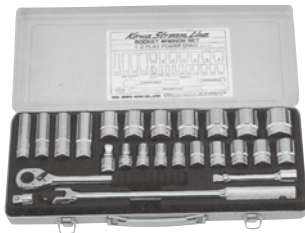

Part name	Part No.	Size	D1	D2	d	L1	L2	Weight (g)
		S						
Standard socket	KLK-2-11	10	15	21	8	42	7	52
	KLK-2-13	12	17.6	21	10	42	8	55
	KLK-2-14	13	18.8	22	11	42	8	62
	KLK-2-15	14	20	22	12	42	10	63
	KLK-2-18	17	24	23	13	42	10	84
	KLK-2-20	19	26.8	26	17.5	42	12	97
	KLK-2-22	21	29.5	27	19	42	14	110
	KLK-2-22A	22	30	28	19	42	14	119
	KLK-2-23	23	31.5	29	19	42	15	133
	KLK-2-24	24	32	30	19	48	20	150
	KLK-2-26	26	35	32	20	48	21	184
	KLK-2-27	27	37	34	20	48	21	206
	KLK-2-29	29	38	34	21	48	21	202
	KLK-2-29A	30	40	36	23	48	21	234
	KLK-2-30	32	42	38	23	48	22	260
	KLK-2-30B	36	47	44	26	48	22	240
Deep socket	KLK-2-32	14	20.2	21	12	80	15	116
	KLK-2-33	17	24	23	14	80	15	159
	KLK-2-34	19	26.9	26	18.5	80	18	181
	KLK-2-35	21	28.5	27	19	80	21	192

Part name	Part No.	D1	D2	L	Weight (g)
Extension bar	K L -2-4765	16.5	24	50	95
	K L -2-4766	16.5	24	125	157
Nut spinner 1/2 spinner handle	K L K -2-50	20	-	380	750
Ratchet handle	K L -2-4753 G B	38	-	200	510
Conversion socket	K L K -2-93	1/2	3/8	30	38

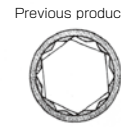

Features

- (1) Thin wall thickness and uncompromising strength are achieved through carefully selected material and processing technology.
- (2) The sockets designed with unique shape come into close contact with the flat head surface of nuts and bolts to prevent damage to the edges.
- (3) Torque applied to the surface of nuts and bolts is conveyed most effectively and evenly to make work easier.
- (4) Socket life is extended by not exerting too much force.

Flat Power Socket Set 3/8SQ KLK-2-201B

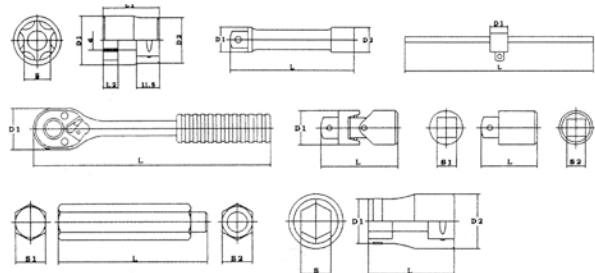

Part name	Part No.	Size	D1	D2	d	L1	L2	Weight (g)	
		S							
Standard socket	KLK-2-210	6	9.4	17	5	32	5	24	
	KLK-2-209	7	10.6	17	6	32	5	24	
	KLK-2-211	8	11.8	17	7	32	6	24	
	KLK-2-212	9	13.2	17	8	32	7	26	
	KLK-2-213	10	14.5	17	8	32	7	29	
	KLK-2-215	12	16.8	17.2	9	32	9	32	
	KLK-2-216	13	18.0	17	10	32	10	33	
	KLK-2-217	14	20.0	18	11	32	10	41	
	KLK-2-218	17	23.6	22	14	32	12	58	
	KLK-2-220	19	26	24	15	32	12	71	
	KLK-2-221	21	28	26	16	32	12	81	
	KLK-2-221A	22	30	27	18	32	13	94	
	KLK-2-223	23	31.5	29	18	32	13	108	
	KLK-2-223A	24	32	30	18	32	13	112	
	Deep socket	KLK-2-222	8	13	16	7	55	7	49
		KLK-2-224	10	14.5	17	8	55	9	49
		KLK-2-226	12	18	17.5	10	55	12	59
		KLK-2-228	14	19.5	18	12	55	15	68
		KLK-2-229	17	23.5	22	12	55	15	99

Part name	Part No.	D1	D2	L	Weight (g)
Extension bar	KL-2-3763	12.5	18	100	70
	KL-2-3764	12.5	18	250	96
Slide handle	KLK-2-255	20	-	250	261
Ratchet handle	KL-2-3753GB	32	-	200	270
3/8 universal joint	KLK-2-275	19	-	52.5	70

Part No.	Part No.	Size		L	Weight (g)
		S1	S2		
3/8 x 1/2 conversion socket	KLK-2-93	1/2	3/8	30	38

Part No.	Part No.	Size	S1	S2	L	Weight (g)					
		S1									
		Hex bit					KLK-16-211	4	8	80	30
							KLK-16-212	5	8	80	30
							KLK-16-213	6	8	80	30
KLK-16-214	8		8	80	30						

Part No.	Part No.	Size	D1	D2	L	Weight (g)
		S1				
Bit holder	KLK-16-201	8	16	18.5	38	54

This comprehensive set contains invaluable tools such as hex bits and deep sockets. (3/8SQ)

Hand Tools

Standard Socket Wrench 1/4SQ (6-angle Specification)



Part No.	Size	Depth (mm)	Total length (mm)
KL-2-2403R	3	3	22
KL-2-2404R	4	3.8	22
KL-2-2404AR	4.5	4.2	22
KL-2-2405R	5	4.6	22
KL-2-2405AR	5.5	5	22
KL-2-2406R	6	5.4	22
KL-2-2407R	7	6.1	22
KL-2-2408R	8	6.8	22
KL-2-2409R	9	7.5	22
KL-2-2410R	10	8.2	22
KL-2-2411R	11	8.9	22
KL-2-2412R	12	9.6	22
KL-2-2413R	13	10.3	22
KL-2-2414R	14	11	24

Deep Socket Wrench 1/4SQ (6-angle Specification)



Part No.	Size	Size (mm)	Total length (mm)
KL-2-2305R	5	4.6	22
KL-2-2306R	6	5.4	22
KL-2-2307R	7	6.1	22
KL-2-2308R	8	6.8	22
KL-2-2309R	9	7.5	22
KL-2-2310R	10	8.2	22
KL-2-2311R	11	8.9	22
KL-2-2312R	12	9.6	22

Standard Socket Wrench 3/8SQ (6-angle Specification)



Part No.	Size	Depth (mm)	Total length (mm)
KL-2-3406R	6	6	26
KL-2-3407R	7	6.5	26
KL-2-3408R	8	7	26
KL-2-3409R	9	7.5	26
KL-2-3410R	10	8	26
KL-2-3411R	11	8.5	26
KL-2-3412R	12	9	26
KL-2-3413R	13	9.5	26
KL-2-3414R	14	11	27
KL-2-3415R	15	11.5	28
KL-2-3416R	16	12	28
KL-2-3417R	17	12.5	29
KL-2-3418R	18	13	30
KL-2-3419R	19	13.5	30
KL-2-3420R	20	14	31
KL-2-3421R	21	14.5	32
KL-2-3422R	22	15	32
KL-2-3423R	23	15.5	33

Deep Socket Wrench 3/8SQ (6-angle Specification)



Part No.	Size	Depth (mm)	Total length (mm)
KL-2-3306R	6	7	55
KL-2-3307R	7	8	55
KL-2-3308R	8	9	55
KL-2-3309R	9	10	55
KL-2-3310R	10	11	55
KL-2-3311R	11	12	55
KL-2-3312R	12	13	55
KL-2-3313R	13	14	55
KL-2-3314R	14	16	55
KL-2-3315R	15	16	55
KL-2-3316R	16	17	55
KL-2-3317R	17	18	55
KL-2-3318R	18	19	55
KL-2-3319R	19	20	55
KL-2-3321R	21	22	65
KL-2-3322R	22	23	65
KL-2-3323R	23	24	65

Standard Socket Wrench 1/2SQ (6-angle Specification)



Part No.	Size	Depth (mm)	Total length (mm)
KL-2-4408R	8	8	36
KL-2-4409R	9	8.5	37
KL-2-4410R	10	9	37
KL-2-4411R	11	9.5	37
KL-2-4412R	12	10	37
KL-2-4413R	13	10.5	37
KL-2-4414R	14	11	37
KL-2-4415R	15	11.5	37
KL-2-4416R	16	12	37
KL-2-4417R	17	12.5	37
KL-2-4418R	18	13	37
KL-2-4419R	19	14	38
KL-2-4420R	20	15	38
KL-2-4421R	21	15.5	38
KL-2-4422R	22	16	40
KL-2-4423R	23	16.5	40
KL-2-4424R	24	17	42
KL-2-4425R	25	18	42
KL-2-4426R	26	19	42
KL-2-4427R	27	19.5	43
KL-2-4428R	28	20	43
KL-2-4429R	29	20.5	43
KL-2-4430R	30	22	46
KL-2-4431R	31	22.5	46
KL-2-4432R	32	23	46

Deep Socket Wrench 1/2SQ (6-angle Specification)



Part No.	Size	Depth (mm)	Total length (mm)
KL-2-4308R	8	9	77
KL-2-4309R	9	10	77
KL-2-4310R	10	11	77
KL-2-4311R	11	12	77
KL-2-4312R	12	13	77
KL-2-4313R	13	14	77
KL-2-4314R	14	15	77
KL-2-4315R	15	16	77
KL-2-4316R	16	17	77
KL-2-4317R	17	18	77
KL-2-4318R	18	19	77
KL-2-4319R	19	20	77
KL-2-4320R	20	21	77
KL-2-4321R	21	23	77
KL-2-4322R	22	27	77
KL-2-4323R	23	27	77
KL-2-4324R	24	27	77
KL-2-4325R	25	27	77
KL-2-4326R	26	27	77
KL-2-4327R	27	28	77
KL-2-4328R	28	28	77
KL-2-4329R	29	28	77
KL-2-4330R	30	34	77
KL-2-4331R	31	34	77
KL-2-4332R	32	34	77

Conversion Adapters

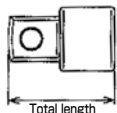

Part No.	Size	Total length (mm)
KL-2-2233	Depression 1/4 x protrusion 3/8	22
KL-2-3322A	Depression 3/8 x protrusion 1/4	24
KL-2-3344A	Depression 3/8 x protrusion 1/2	30
KL-2-4433A	Depression 1/2 x protrusion 3/8	35
KL-2-4466A	Depression 1/2 x protrusion 3/4	42
KL-2-6644A	Depression 3/4 x protrusion 1/2	47
KL-2-6688A	Depression 3/4 x protrusion 1/2	60

Universal Joint



Part No.	Size	Total length (mm)
KL-2-2770	Protrusion 1/4	33
KL-2-3770	Protrusion 3/8	50
KL-2-4770	Protrusion 1/2	30
KL-2-6770	Protrusion 3/4	35

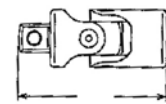
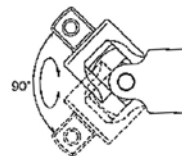

Hand Tools

Standard Impact Socket 3/8SQ



Part No.	Size	Depth (mm)	Total length (mm)
KH-2-13408	8	6	32
KH-2-13409	9	7	32
KH-2-13410	10	7	33
KH-2-13411	11	8	33
KH-2-13412	12	9	34
KH-2-13413	13	10	34
KH-2-13414	14	10	35
KH-2-13415	15	11	35
KH-2-13416	16	11	38
KH-2-13417	17	12	38
KH-2-13418	18	12	40
KH-2-13419	19	12	40
KH-2-13421	21	12	13

Deep Impact Socket 3/8SQ



Part No.	Size	Depth (mm)	Total length (mm)
KH-2-13307	7	7	80
KH-2-13308	8	8	80
KH-2-13309	9	9	80
KH-2-13310	10	10	80
KH-2-13311	11	11	80
KH-2-13312	12	12	80
KH-2-13313	13	13	80
KH-2-13314	14	14	80
KH-2-13315	15	15	80
KH-2-13317	17	17	80
KH-2-13319	19	19	80
KH-2-13321	21	21	80
KH-2-13322	22	22	80

Standard Impact Socket 1/2SQ



Part No.	Size	Depth (mm)	Total length (mm)
KH-2-14408	8	6	38
KH-2-14409	9	7	38
KH-2-14410	10	7	38
KH-2-14411	11	8	38
KH-2-14412	12	9	38
KH-2-14413	13	10	38
KH-2-14414	14	10	38
KH-2-14415	15	11	38
KH-2-14416	16	11	38
KH-2-14417	17	12	38
KH-2-14418	18	13	38
KH-2-14419	19	13	38
KH-2-14421	21	14	38
KH-2-14422	22	14	38
KH-2-14423	23	14	38
KH-2-14424	24	14	38
KH-2-14426	26	14	38
KH-2-14427	27	16	40
KH-2-14428	28	16	40
KH-2-14429	29	17	42
KH-2-14430	30	17	42

Deep Impact Socket 1/2SQ



Part No.	Size	Depth (mm)	Total length (mm)
KH-2-14310	10	10	80
KH-2-14311	11	11	80
KH-2-14312	12	12	80
KH-2-14313	13	13	80
KH-2-14314	14	14	80
KH-2-14315	15	15	80
KH-2-14317	17	17	80
KH-2-14318	18	18	80
KH-2-14319	19	19	80
KH-2-14321	21	21	80
KH-2-14322	22	22	85
KH-2-14323	23	23	85
KH-2-14324	24	24	85
KH-2-14326	26	26	85
KH-2-14327	27	27	85

Impact Extension bar 3/8SQ



Part No.	Total length (mm)
KH-2-13760	75
KH-2-13761	125
KH-2-13762	250

Impact Extension bar 1/2SQ



Part No.	Total length (mm)
KH-2-14760	75
KH-2-14761	125
KH-2-14762	250

Impact Conversion Adapter



Part No.	Total length (mm)
KH-2-14466A	Depression 1/2" x protrusion 3/4"
KH-2-14433A	Depression 1/2" x protrusion 3/8"
KH-2-13344A	Depression 3/8" x protrusion 1/4"

Impact Universal Joint



Part No.	SQ	Total length (mm)
KH-2-14770	1/2	74
KH-2-13770	3/8	45

Screwdriver Bit (+)



Part No.	Part Name	Total length (mm)
KH-1-123PN10002	Screwdriver bit (plus) No.2	100
KH-1-123PN10003	Screwdriver bit (plus) No.3	100

Hex Bit



Part No.	Part Name	Total length (mm)
KH-1-121H7004	Hex pit 4 mm	70
KH-1-121H7005	Hex pit 5 mm	70
KH-1-121H7006	Hex pit 6 mm	70

Socket Bit



Part No.	Part Name	Total length (mm)
KH-1-1137508	Socket pit 8 mm	75
KH-1-1137510	Socket pit 10 mm	75
KH-1-1137512	Socket pit 12 mm	75
KH-1-1137513	Socket pit 13 mm	75
KH-1-1137514	Socket pit 14 mm	75

Impact Bit holder



Part No.	Part Name
KH-2-13137H	Depression 3/8SQ
KH-2-14137E	Depression 1/2SQ

Hand Tools

Hex Bit Socket 1/4SQ



1/4SQ Hex Bit 25 mm

Part No.	Size	Width (mm)	Total length (mm)
KL-2-2010M25025	2.5	12	25
KL-2-2010M2503	3	12	25
KL-2-2010M2504	4	12	25
KL-2-2010M2505	5	12	25
KL-2-2010M2506	6	12	25
KL-2-2010M2507	7	13.1	25
KL-2-2010M2508	8	13.1	25
KL-2-2010M2510	10	13.1	25

1/4SQ Hex Bit 100 mm

Part No.	Size	Width (mm)	Total length (mm)
KL-2-2010M100025	2.5	12	100
KL-2-2010M10003	3	12	100
KL-2-2010M10004	4	12	100
KL-2-2010M10005	5	12	100
KL-2-2010M10006	6	12	100
KL-2-2010M10007	7	13.1	100
KL-2-2010M10008	8	13.1	100
KL-2-2010M10010	10	13.1	100

Hex Bit Socket 3/8SQ



3/8SQ Hex Bit 38 mm

Part No.	Size	Width (mm)	Total length (mm)
KL-2-3010M3803	3	18	38
KL-2-3010M3804	4	18	38
KL-2-3010M3805	5	18	38
KL-2-3010M3806	6	18	38
KL-2-3010M3807	7	18	38
KL-2-3010M3808	8	18	38
KL-2-3010M3810	10	20	38
KL-2-3010M3812	12	20	38
KL-2-3010M3813	13	22	38
KL-2-3010M3814	14	22	38

3/8SQ Hex Bit 100 mm

Part No.	Size	Width (mm)	Total length (mm)
KL-2-3010M10003	3	18	100
KL-2-3010M10004	4	18	100
KL-2-3010M10005	5	18	100
KL-2-3010M10006	6	18	100
KL-2-3010M10007	7	18	100
KL-2-3010M10008	8	18	100
KL-2-3010M10010	10	20	100
KL-2-3010M10012	12	20	100
KL-2-3010M10013	13	22	100
KL-2-3010M10014	14	22	100

Hex Bit Socket 1/2SQ



1/2SQ Hex Bit 50 mm

Part No.	Size	Width (mm)	Total length (mm)
KL-2-4010M5004	4	21.1	50
KL-2-4010M5005	5	21.1	50
KL-2-4010M5006	6	21.1	50
KL-2-4010M5007	7	21.1	50
KL-2-4010M5008	8	21.1	50
KL-2-4010M5010	10	23	50
KL-2-4010M5012	12	24	50
KL-2-4010M5014	14	24	50
KL-2-4010M5017	17	24	50
KL-2-4010M5019	19	24	50

1/2SQ Hex Bit 100 mm

Part No.	Size	Width (mm)	Total length (mm)
KL-2-4010M10004	4	21.1	100
KL-2-4010M10005	5	21.1	100
KL-2-4010M10006	6	21.1	100
KL-2-4010M10007	7	21.1	100
KL-2-4010M10008	8	21.1	100
KL-2-4010M10010	10	23	100
KL-2-4010M10012	12	24	100
KL-2-4010M10014	14	24	100
KL-2-4010M10017	17	24	100
KL-2-4010M10019	19	24	100

Torx Bit Socket 1/4SQ (Tinker Prevention)



Part No.	Size	Width (mm)	Total length (mm)
KL-2-202528T10H	T10H	12	28
KL-2-202528T15H	T15H	12	28
KL-2-202528T20H	T20H	12	28
KL-2-202528T25H	T25H	12	28
KL-2-202528T27H	T27H	12	28
KL-2-202528T30H	T30H	12	28
KL-2-202528T40H	T40H	12	28

Torx Bit Socket 3/8SQ (Tinker Prevention)



3/8SQ Torx Bit Socket 50 mm

Part No.	Size	Width (mm)	Total length (mm)
KL-2-302550T10H	T10H	18	50
KL-2-302550T15H	T15H	18	50
KL-2-302550T20H	T20H	18	50
KL-2-302550T25H	T25H	18	50
KL-2-302550T27H	T27H	18	50
KL-2-302550T30H	T30H	18	50
KL-2-302550T40H	T40H	18	50

Torx Bit Socket 3/8SQ (Long)



3/8SQ Torx Bit Socket 100 mm (Cylindrical Shaft)

Part No.	Size	Width (mm)	Total length (mm)
KL-2-3025100RT20H	T20H	18	100
KL-2-3025100RT25H	T25H	18	100
KL-2-3025100RT27H	T27H	18	100
KL-2-3025100RT30H	T30H	18	100
KL-2-3025100RT40H	T40H	18	100
KL-2-3025100RT45H	T45H	20	100
KL-2-3025100RT50H	T50H	20	100

3/8SQ Torx Bit Socket 160 mm

Part No.	Size	Width (mm)	Total length (mm)
KL-2-3025160T25H	T25H	18	160
KL-2-3025160T27H	T27H	18	160
KL-2-3025160T30H	T30H	18	160
KL-2-3025160T40H	T40H	18	160
KL-2-3025160T45H	T45H	18	160
KL-2-3025160T50H	T50H	20	160
KL-2-3025160T55H	T55H	20	160

Impact Hex Bit Socket 3/8SQ



3/8SQ Impact Hex Bit Socket 52 mm

Part No.	Size	Width (mm)	Total length (mm)
KH-2-13012M5204	4	18	52
KH-2-13012M5205	5	18	52
KH-2-13012M5206	6	18	52
KH-2-13012M5208	8	21	52
KH-2-13012M5210	10	21	52
KH-2-13012M5212	12	21	52

Impact Hex Bit Socket 1/2SQ



1/2SQ Impact Hex Socket 60 mm

Part No.	Size	Width (mm)	Total length (mm)
KH-2-14012M6004	4	25	60
KH-2-14012M6005	5	25	60
KH-2-14012M6006	6	25	60
KH-2-14012M6008	8	25	60
KH-2-14012M6010	10	30	60
KH-2-14012M6012	12	30	60
KH-2-14012M6014	14	30	60
KH-2-14012M6017	17	30	60
KH-2-14012M6019	19	30	60

Hand Tools

Extension Bar 1/4SQ

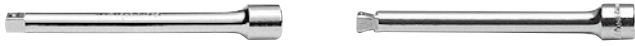

1/4SQ Extension bar

Part No.	Width (mm)	Total length (mm)
KL-2-2760028	12.3	28
KL-2-2760050	12.3	50
KL-2-2760100	12.3	100
KL-2-2760150	12.3	150
KL-2-2760200	12.3	200
KL-2-2760250	12.3	250
KL-2-2760300	12.3	300
KL-2-2760350	12.3	350
KL-2-2760400	12.3	400
KL-2-2760600	12.3	600

1/4SQ Offset Extension bar

Part No.	Width (mm)	Total length (mm)
KL-2-2763028	12.3	28
KL-2-2763050	12.3	50
KL-2-2763100	12.3	100
KL-2-2763150	12.3	150
KL-2-2763200	12.3	200
KL-2-2763250	12.3	250

Extension Bar 3/8SQ



3/8SQ Extension bar

Part No.	Width (mm)	Total length (mm)
KL-2-3760032	18	32
KL-2-3760050	18	50
KL-2-3760075	18	75
KL-2-3760125	18	125
KL-2-3760250	18	250
KL-2-3760300	18	300
KL-2-3760400	18	400
KL-2-3760500	18	500
KL-2-3760600	18	600
KL-2-3760900	18	900
KL-2-37601000	18	1000

3/8SQ Offset Extension bar

Part No.	Width (mm)	Total length (mm)
KL-2-3763032	18	32
KL-2-3763050	18	50
KL-2-3763075	18	75
KL-2-3763125	18	125
KL-2-3763250	18	250
KL-2-3763300	18	300

Extension Bar 1/2SQ



1/2SQ Extension bar

Part No.	Width (mm)	Total length (mm)
KL-2-4760050	24	50
KL-2-4760075	24	75
KL-2-4760125	24	125
KL-2-4760250	24	250
KL-2-4760300	24	300
KL-2-4760400	24	400
KL-2-4760500	24	500
KL-2-4760600	24	600
KL-2-4760900	24	900
KL-2-47601000	24	1000

1/2SQ Offset Extension bar

Part No.	Width (mm)	Total length (mm)
KL-2-4763050	24	50
KL-2-4763075	24	75
KL-2-4763125	24	125
KL-2-4763250	24	250

Slim Plug Wrench 3/8SQ

14 mm KL-2-3300CZ14 16 mm KL-2-3300CZ16

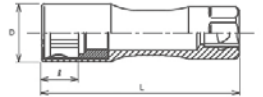

3300CZ (mm)	D (mm)	f (mm)	L (mm)	Weight (g)
14	18.4	11	70	67
16	20.5	13	70	71

By shaving away any surplus parts in the middle of the socket to the utmost limit, this thin-walled plug wrench can be used for scooters with narrow access to spark plugs.

14 mm: FORZA/FORESIGHT

16 mm: Compact scooters, etc.

· 3/8SQ (with 17 mm hex hole) · Spring lock type

Long Ratchet Offset Wrenches



Part No.	Size	Total length
KL-3-FRC10L	10 mm	312 mm
KL-3-FRC12L	12 mm	312 mm
KL-3-FRC14L	14 mm	394 mm
KL-3-FRC17L	17 mm	394 mm

This swing ratchet is perfect for difficult-to-reach nuts and bolts. These straight long offset wrenches are perfect for getting to recessed hard nuts and bolts. They can also be used for final tightening!

Ratchet Slim Wrenches

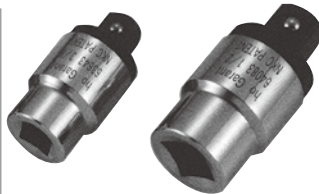

Part No.	Size	Total length
KL-2-RSS95	3/8SQ	46 mm
KL-2-RSS127	1/2SQ	58 mm

Ratchet adapters rotate fully even when there is little feed with gearless non-step feed mechanisms, and can even be used in tight spaces.

Universal Tool Mini



Part No.	Size	Total length
KL-2-UVS10	10 mm	105 mm
KL-2-UVS12	12 mm	105 mm
KL-2-UVS14	14 mm	120 mm
KL-2-UVS17	17 mm	120 mm

The built-in universal employs a ball joint system, and the force is always supported at 4 points, ensuring that rotation is smooth and robust. These tools can be rotated with spanners, boxes, or offset wrenches.

Plate Ratchet



Part No.	Size	L (mm)
KL-3-PR0810	8 x 10 mm	115
KL-3-PR1012	10 x 12 mm	140
KL-3-PR1113	11 x 13 mm	165
KL-3-PR1214	12 x 14 mm	165
KL-3-PR1417	14 x 17 mm	190
KL-3-PR1719	17 x 19 mm	215
KL-3-PR1721	17 x 21 mm	215
KL-3-PR1921	19 x 21 mm	226
KL-3-PR1922	19 x 22 mm	226

This plate ratchet is equipped with an adapter for quick rotation, now enabling socket attachment also.

Semi-deep Socket Set 3/8SQ KL-2-760



Indispensable set of tools with total length of 40 mm. 8, 10, 12, 14, 17, 19 mm With rail

Ultra-long Socket 3/8SQ Set of 3 KL-2-DS314SL

Ultra-long Socket 3/8SQ 14 mm KL-2-DS3SSL



With total length of 120 mm, these sockets are useful for attaching and removing deeply located bolts. * Set of 3 comprising 8, 10, and 12 mm sockets. The 14 mm socket is extremely useful for rotating scooter drum brake adjustment nuts.

Ratchet Puller Set

Set of 4 KL-2-1201



<Sold individually>

KL-14-141S6	6 mm
KL-14-141S8	8 mm
KL-14-141S10	10 mm
KL-14-141S12	12 mm

The ratchet type puller is used for repeated tightening in the same direction. As these are through-type pullers, they can be used for chucking at deep bolt locations. This three-roller construction makes screw thread makes damage difficult, and the non-slip rubber handle makes it ideal for attaching and removing stud bolts.

Mini Reverse Gear Ratchet Set KL-2-MRG1431S



This set comprises 27 bits in addition to a useful mini reverse gear ratchet, magnetic bit holder, and socket adapter.

● Number of gears: 48 ● Total length: 90 mm ● Insertion angle 1/4SQ

Hand Tools

Compact Bit Ratchet Set KLK-1-52528B



Set contents:

- Straight ratchet handle
- Stubby handle
- Magnetic bit holder
- Plus bit: No.1, No.2, No.3
- Minus bit: 6 mm
- Hex bits: 2.5, 3.0, 4.0, 5.0, 6.0 mm
- Torx: T6, T8, T10, T15, T20, T25, T27, T30, T40
- No holes for tinker prevention in T6.
- Hex sockets: 5.0, 5.5, 6.0, 7.0, 8.0, 9.0, 10.0, 11.0, 12.0, 13.0 mm

Screw Removal Impact Set KL-1-1903N

Dedicated screw removal tool!
Compatible with both pan head screws and countersunk screws.



Set contents:
Mini impact screwdriver
Bit holder (6.35 mm)
Screw removal bit
Plus No.2 x 30 mm

Bearing Remover Set KLK-31-3

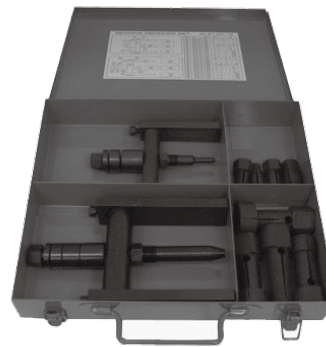

Set including 8 sizes of remover and body

Corresponding bearing inner diameter (set component parts) Dedicated body x 2

Part No.	Part Name
KLK-31-1-A10	10 mm
KLK-31-1-A11	12 mm
KLK-31-1-A12	15 mm
KLK-31-1-A13	17 mm
KLK-31-1-B11	20 mm
KLK-31-1-B12	25 mm
KLK-31-1-B13	30 mm
KLK-31-1-B14	35 mm

* 8 mm (sold separately) Part No.: KLK-31-1-A17

Plug Wrench Set 3/8SQ KLK-2-403A

- Ideal for use in tight spaces.
- With easy-to-use extension
- Can also be rotated with 17 mm offset spanner, etc.



<Sold individually>

Part No.	Part Name
KLK-2-404	M10 plug wrench
KLK-2-405	M12 plug wrench
KLK-2-406A	M14 plug wrench
KLK-2-407	15 mm extension bar
KLK-2-408	30 mm extension bar

Universal Plug Wrench 16 mm Set KLK-2-NP400



Concerns over coming free of sockets have been eliminated by employing a push-cancel type extension bar. For C plugs insert lightly and swing 15°. Plug wrench with universal: 16 mm
Extension bars: 75, 125 mm, one of each

13 mm Plug Wrench KL-2-413P



For E plugs
Screw diameter 8 mm

Plug Wrench with T-type Joint



Part No.	Size	Total length (mm)
KL-4-51	10	480
KL-4-52	12	480
KL-4-53	14	480

Flywheel Puller



Compatible with M27 x 1.0 left screw flywheels, rotors

Compatible with M16 x 1.5 right screw flywheels, rotors

Compatible with M24 x 1.0 right screw flywheels, rotors

Usage example



Part No.	Part Name
KLK-33-001	Flywheel puller (for M16)
KLK-33-011	Flywheel puller (for M27 left screw)
KLK-33-012	Flywheel puller (for M24)

Flywheel Holder 2K-L-FWH0100



Flywheel rotation stopper
Compatible size
115 to 160 mm

Universal Holder 2K-L-UH0100



This tool is used to prevent rotation of flywheels, drive sprockets, etc.
Max. width: 99 mm

Clutch Center Holder 2K-L-CCH0100



Compatible size
48 to 135 mm

Hand Tools

Front Fork Spring Compressor 2K-F-10



Indispensable tool for front fork disassembly and maintenance!

Stand for front fork disassembly capable of being carried out by one person

* In addition to the unit, dedicated tool and jacks indicated in the service manuals of the respective manufacturers are required.

Fork Bolt Socket 45 mm Octagonal 2K-L-FBW001

For SHOWA big piston inverter front forks adopted on CBR1000RR.
Plastic socket Insertion angle: 1/2SQ
Torque: 50 N·m or less

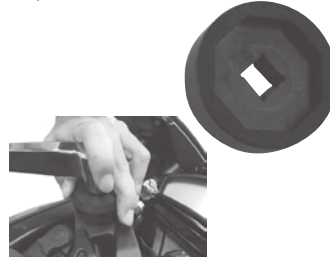

Fork Bolt Socket 24 mm Hex 2K-L-FB24

Made of plastic to protect aluminum fork bolts.
* Used for CB1300SF.
Insertion angle: 1/2SQ
Max. torque: 50 N·m

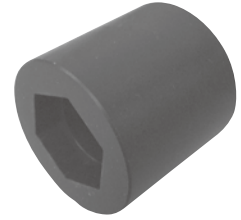

Front Fork Tool Seal Driver KLK-64-100



Inverted forks can also be stored!
Support for 26 to 46 mm

Front Fork Tool Screwdriver ATT (for 48 to 54 mm) KLK-64-5



Screwdriver ATT

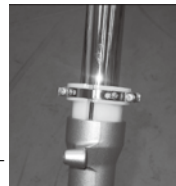

Set the oil seal and this tool (ATT) on the outer tube.

Front Fork Seal Driver Weight (for 48 to 54 mm) KLK-64-6



Driver weight



Using this tool (weight), hammer the ATT to pressure fit the oil seal.

Adjustable Hook Wrench 2K-L-PS0100



This is an adjustable hook wrench. Torque management is possible with a 3/8" insertion angle. Compatible size $\phi 35$ to 65

Steering Stem Wrench 2K-L-40

(12-point)

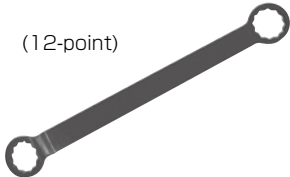

Used for disassembling the steering stem. Stem nuts can be removed and attached without removing the handle bar. No handle bar adjustments are required when assembling, and handle bar securing bolt trouble can be eliminated.
● Total length: 340 mm 30 × 32 mm

Stem Nut Wrench 29 mm 2K-L-41

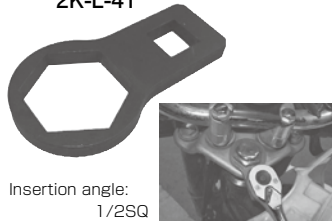

Insertion angle: 1/2SQ

Used for models with narrow gap between stem nuts and the handle for which torque management with standard tools is impossible.

With this tool, attachment and removal is possible without removing the handle, and torque can be managed by also using a torque wrench.

Hex Bit for Front Axle

Large hex bit socket ideal for hex holes on motorcycle front axle shafts.



Insertion angle: 1/2SQ

Part No.	Size
KL-2-4012M4314	14mm
KL-2-4012M4317	17 mm
KL-2-4012M4319	19 mm
KL-2-4012M4320	20 mm
KL-2-4012M4321	21 mm
KL-2-4012M4322	22 mm
KL-2-4012M4324	24 mm
KL-2-4012M4327	27 mm

Stand Spring Setter KL-9-C141



When replacing side stand and center stand springs, new springs can be fitted easily by applying the principle of leverage. Total length: 140 mm

PCX Rear Swing Arm Pulley 2K-L-SAP0100

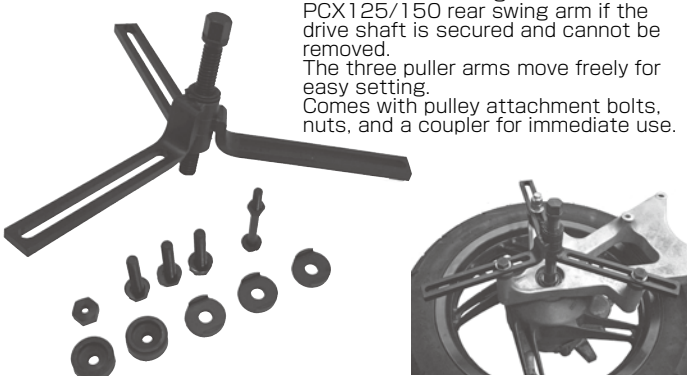

Used when removing the PCX125/150 rear swing arm if the drive shaft is secured and cannot be removed. The three puller arms move freely for easy setting. Comes with pulley attachment bolts, nuts, and a coupler for immediate use.

Scooter Drive Belt Case Pulley 2K-L-BCP0100

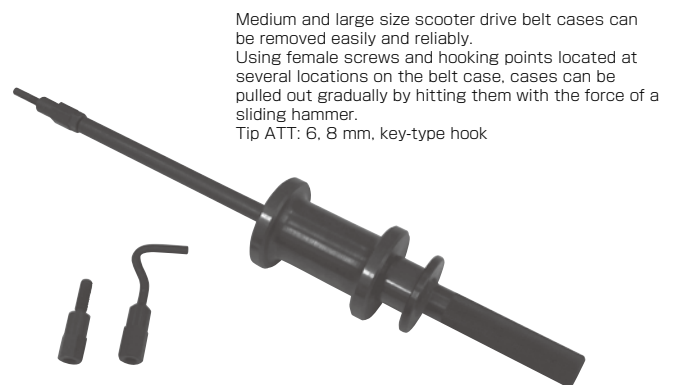

Medium and large size scooter drive belt cases can be removed easily and reliably. Using female screws and hooking points located at several locations on the belt case, cases can be pulled out gradually by hitting them with the force of a sliding hammer. Tip ATT: 6, 8 mm, key-type hook

Hand Tools

Plastic Remover Set of 5
KL-9-LB502



Made of plastic to prevent scratches when carrying out scooter cover and cowl disassembly work. Five types of odd-form head can be used in a variety of locations.

Plastic Remover Set of 8
KL-9-LB504



With sharper tip, these removers can be easily inserted into tight gaps. Made of hard material and sharp, they can be used like scrapers. Total length: 205 mm Weight: 300 g

Pick Tool Set
KL-9-LB607



Convenient pick tool for removing o-rings and fine parts. Four types of tip and an extension adapter can be stored inside the grip body. Total grip length: 127 mm Weight: 70 g

Brake Piston Tool
KFK-21-10SW



Compact size ideal for work involving returning bike disc brake pistons. Plate max. 52 mm, min. 9 mm

Float Valve Sheet Cleaner Set
KEK-56-10

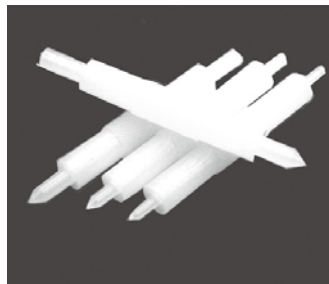

Excellent for cleaning the front valve contact surface of carburetors. Set of 4 (with case): $\phi 3.5$, $\phi 4$, $\phi 5.3$, $\phi 5.7$

Tail Pipe Cleaner
2K-P-01



2 cycle scooter type vehicle muffler cleaning tool
* Please use a power drill.

Oil Seal Remover
KLK-31-5SW



Oil seals up to 70 mm can be easily removed by employing the principal of leverage. Total length: 255 mm

Oil Stone Fine
KL-24-2

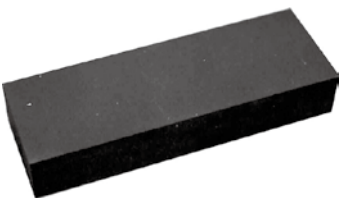

External size: 100 × 25 × 13 mm

Scraper Set
KL-13-LB608

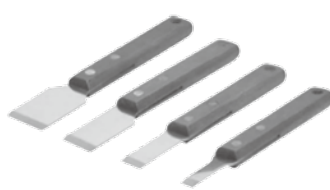

Blade width: 4 types: 10, 15, 23, 30 mm
Total grip length: 127 mm

Terminal Kit B Type
KL-10-1A



Standard wiring repair tool

Chain Cut & Caulking Tool Set
KLK-11-100



#50 chains can be cut and caulked reliably with a simple setup. Total length: 170 mm with case

Pin Tool Set
KLM-101-011



● Useful to terminal attachment and removal inside couplers.

Hose Clip Set of 2
KL-7-25



● Equipped with lock, and used to provided support when temporarily holding down fuel hoses, negative pressure hoses.

Line Clamp (S) 150 mm KL-7-UL1801B
Line Clamp (L) 182 mm KL-7-UL1801A

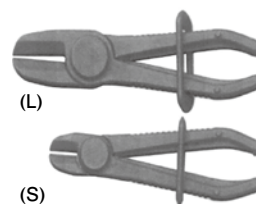

Used to temporarily hold fuel hoses, radiator hoses, and air hoses, etc. Made of plastic to prevent damage to hoses. (L) size is used for radiator hoses, and (S) size is used for fuel hoses.

Gasoline Sub Tank
KL-50-5



Tank capacity: 2 L
Hose length: 1.3 m
With one hose clip.

Disassembly and Maintenance Equipment, Slopes

Engine Disassembly Work Table KPK-50-N35



Ideal for engine disassembly work.
Waste oil accumulates in the plastic tank below.
Size: 660 × 700 × 800 mm

Parts Table KL-50-7



The lower levels are trays, and strength has been improved!

- Weight: 10 kg
- Size: 600 × 365 × 825 mm
- With two steel oil pans

Vice (Applied Type) KL-30-7 Vice (Lead Type) KL-30-3

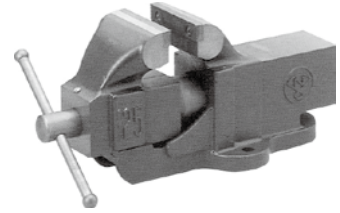

This vice offers excellent durability.
Width: 125 mm

PC Scan Cart Set with Cover KPK-27-70

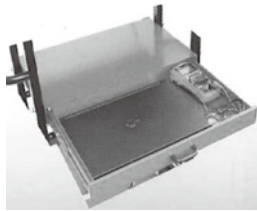

Comes with trays for storage of accessories such as scanning tools or a laptop PC. Holes have been punched in the bottom surface to prevent the accumulation of dirt and dust.

The cart is equipped with a drawer for storage of paper up to A3 size.

- Allows the customer to see the PC screen.
 - Used for organizing and storing wire.
 - Read by everyone for lectures and training.
- With 100 VAC socket
Complete with PC protective cover

SST Spray Stand KP-11-7



Ideal as a work table when machining urethane bumpers.

Heating Gun KJ-15-7



Ideal for plastic repair.
Powerful hot air: 1,000W
Max. temperature: 500 °C
100 VAC

Bench Grinder KI-7-1

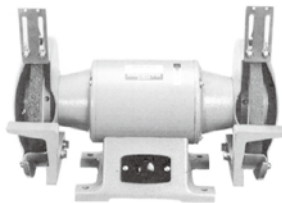

Grindstone diameter: 150 mm
100 VAC

Air Valve Lapper KD-6-3

Air pressure: 0.4 to 0.8MPa
External size: 225 × φ80 mm
Weight: 1,200 g



Part No.	Part Name
KD-6-3	Air valve rubber
KD-6-15	Suction rubber φ 16 mm
KD-6-16	Suction rubber φ 20 mm
KD-6-17	Suction rubber φ 30 mm
KD-6-18	Suction rubber φ 35 mm

Stainless Steel Body Cleaner 30 L KA-8-ZD10

Powerful vacuum cleaner with outstanding cost performance

Attractive and rust-resistant body
Powerful and low-noise motor adopted
Suction power of 1,000W
Noise level of 70 to 73dB (A)
Able to suck up both dirt and water
Powerful vacuum
Liquid full capacity
With auto stop device
Smooth, easy movement
4 independent casters



Aluminum Bridge (Folding Type) KP-51-1 (Straight Type Tabs) KP-51-2 (Hook Type Tabs) KP-51-4

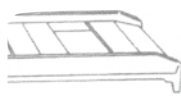
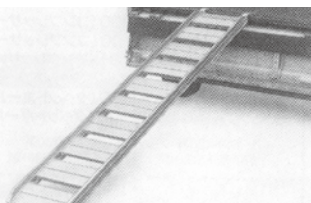

Straight type tab

Hook type tab

Original products can also be made to special order.

Part No.	Shape	Superimposed load (kg)	Length × effective width (mm)	Weight (kg)
KP-51-1	Folding type	300	2100×180	7.3
KP-51-2	Straight type tab	250	1800×300	6.5
KP-51-3	Hook type tab	250	1800×250	6.0

Folding Type Aluminum Bridge (Straight Type Tabs)

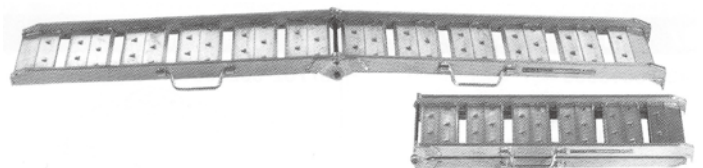

Part No.	Shape	Superimposed load (kg)	Length × effective width (mm)	Weight (kg)
KP-51-BAW210	Straight type tab	250	2100×250	9.0
KP-51-BAW240	Straight type tab	250	2400×250	11.0

Motorcycle Diagnostic Instrument (Standard) 80 km/h Specification KNK-50-40K

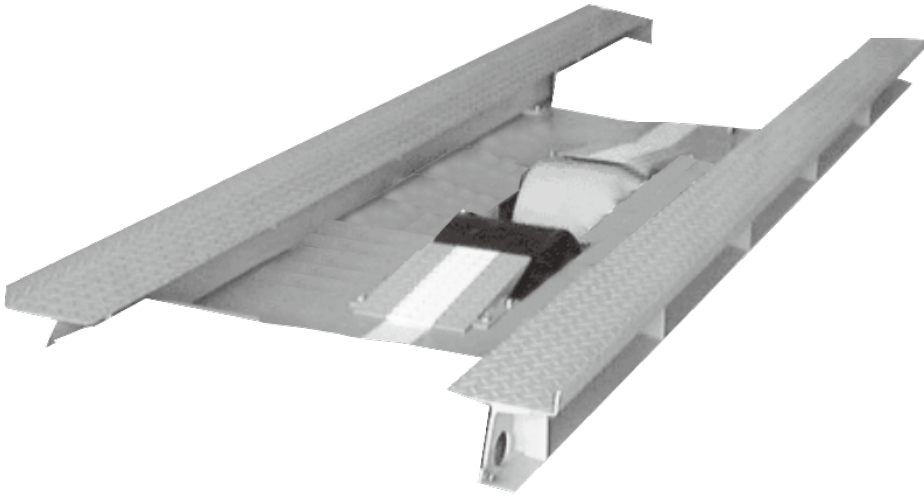

Specifications	
Allowable wheel load	400(kg)
Body	2,000×1,000×500(mm)
Roller	φ370×250(mm)
Distance between shafts	500(mm)
Effective mounting width	300(mm)
Air pressure	0.99(MPa)
Braking force measurement	
Indication method	Digital
Min. scale value	1 (daN)
Usage range	20~240(daN)
Rotation speed	3.05(rpm) 50Hz
Motor	Three-phase 200 V, 0.2kW

Speedometer measurement	
Indication method	Digital
Measurement range	0~160(km/h)
Min. scale	0.1 (km/h)
MD device	
Method	Inverter
Max. drive wheel weight	200(kg)
Max. drive speed	80(km/h)
Motor	Three-phase 200 V, 2.2kW

This is the standard model of specific plant equipment.
Wide tires of 300 mm are also supported.
Standard diagnostic tests on brakes and speed can also be carried out in the workshop.

Motorcycle Diagnostic Instrument (High Grade) 160 km/h Specification KNK-50-160

Optional part

Front wheel clamping device
KNK-50-130-CLAMP
Digital printer
KNK-50-130-DBS
Axle load meter
KNK-50-130-JIKU

Front Wheel Clamping Device

Optional part

Digital printer

Optional part

Guide roller
optional part

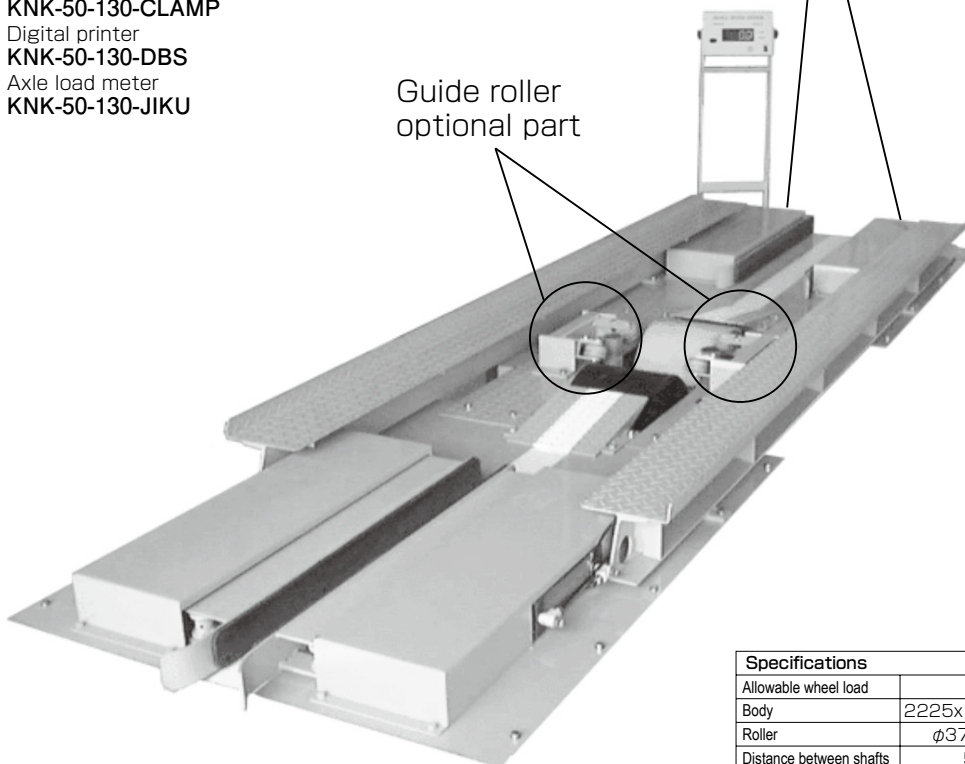

Axle load meter

Optional part

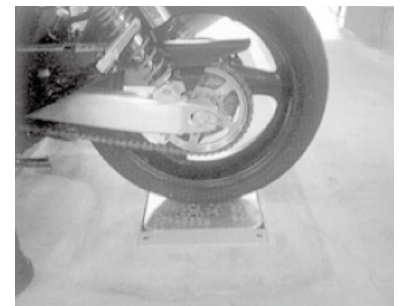

Specifications	
Allowable wheel load	300(kg)
Body	2225x1689x570(mm)
Roller	φ370×250(mm)
Distance between shafts	500(mm)
Effective mounting width	250(mm)
Air pressure	0.99(MPa)
Braking force measurement	
Indication method	Digital
Min. scale value	1 (daN)
Usage range	20~200(daN)
Rotation speed	5.9(rpm) 50Hz
Motor	Three-phase 200 V, 0.75kW

Speedometer measurement	
Indication method	Digital
Measurement range	0~160(km/h)
Min. scale	0.1 (km/h)
MD device	
Method	VSmotor
Max. drive wheel weight	230(kg)
Max. drive speed	130(km/h)
Motor	Three-phase 200 V, 7.5kW

Speedometer tests are possible for high speeds.
This new motorcycle diagnostic instrument employs the latest electronic technology.

Operation is performed with a wireless remote controller.

* Transport costs, installation work, and foundation work are charged separately.

Repair Tools

CO/HC Tester

KN-27-MEXA324L

Carbon monoxide (CO) and hydrocarbons (HC) contained in exhaust gas are measured easily and with high accuracy using the nondispersive infrared (NDIR) absorption method. This allows automobile inspections and services, as well as general engine adjustments to be carried out accurately.

Specifications

- Former Ministry of Transport certified model: MX-002 Category D
- Compatible standard: Equipment Technical Standards for Automobile Inspection
- Vehicles subject to measurement: Gasoline two-wheeled vehicles, gasoline four-wheeled vehicles, LPG four-wheeled vehicles
- Measurement principle: CO 0.00 to 10.00% vol, HCO to 10.000 ppm vol
- Response speed: 15 sec. or less for Td+T95
- Repeatability: Within CO 0.06% vol, or within 5% of indicated value (the larger of the two values)
Within HC 12ppm vol, or within 5% of indicated value (the larger of the two values)
- Warm-up time: 5 min.
- Installation environment: Ambient temperature 0 to 400 °C, relative humidity 90% RH or less
- Display: LCD screen display
- External I/O format: Digital I/O (RS-232C (standard)), printer output (RS-232C)
- Calibration gas: Dedicated cylinders (CO, C3H8)
- Power supply: 100 VAC (85 to 110 V), 50/60Hz, single-phase
- Power consumption: Approx. 50VA
- External size: 260 (W) × 357 (D) × 157 (H) mm
- Weight: Approx. 4 kg

Options

- Serial printer
- Printer cable (15 m)
- Software for external communication
- RS-232C I/O cable (2.5/5/10 m)
- Analog output board
- Analog output cable (3 m)
- Probe
- Drain separator (externally attached type)



Now equipped with RS-232C as standard, enabling data processing with digital input/output!

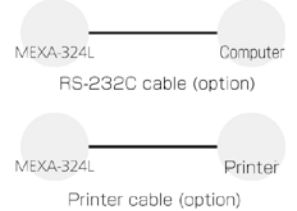

CO/HC Tester Attachment (Simple Type)

2K-N-05

Item required for exhaust gas tester

A test probe can be inserted 600 mm or more, enabling accurate measurement. The attachment is pressed against the muffler, and the probe is inserted.
Size: 655 × Φ55 mm (silicon rubber part)
Weight: 350 g (lightweight aluminum body)

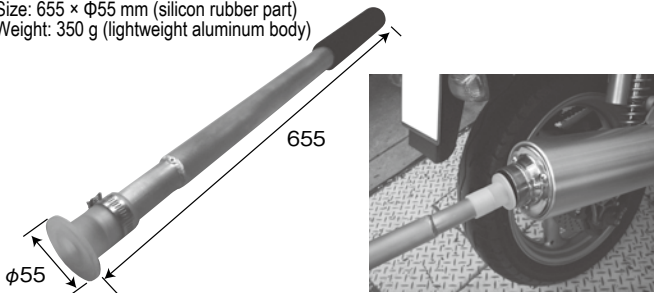

Noise Meter

KN-9-NL27

Features

- Equipped with four measurement functions. Measurement of noise level Lp, equivalent noise level Leq, single event sound exposure level LE, and noise level maximum value Lmax are possible.
- Measurement is performed the moment the power is turned ON. The meter starts up fast for A characteristic when the power is turned ON, allowing measurement to be performed immediately.
- Simple key operation with no need for range switching. Three key switches are used for simple operation, and all 30 dB measurement ranges are covered in a single range, meaning that no troublesome range switching is required.
- Easy-to-view LCD screen. The large LCD screen offers excellent visibility outdoors, and bar graphs that present values in an easy-to-view format and help to detect noise changes are employed.
- The setting procedure is located inside the slide cover. The slide cover contains a handy procedure manual describing how to set Fast/Slow and the measurement time for use in the field.



Volume Indicator

KN-9-IM2801

- Conforms to technical standards relating to equipment for automobile inspections stipulated by the Minister of Land, Infrastructure and Transport.
- Corrections made by the Japan Automotive Service Equipment Association (JASEA) once a year can be accepted at the same time as those for other automobile inspection equipment.
- Operation is performed using the cursor while viewing the screen, offering operability similar to that of a mobile phone, and enabling measurement without any special knowledge or technology.
- Measurement results are display on an LCD display (with backlight) with both bar graphs and values.
- Measurement data can be saved, and an RS-232C interface is provided as standard.
- The volume indicator can be connected to a computer for easy data management and modification. (Data management software is optional.)
- Can be used with two AAA-size batteries. (AC adapter option: IM2801-3000)



Measurement level	A characteristic	30 to 130 dB
	C characteristic	36 to 130 dB
Range		60 to 130 dB, 30 to 100 dB
Measurement time		10 sec., 1, 5, 10, 15, 30 min., 1, 8, 12, 24 hrs.
		Max. measurement time: 199 hrs. 59 min. 59 sec.
Output terminal (switchable)	AC output	1 V/120 dB (range full scale)
	DC output	2.5 V/range full scale
I/O terminal	RS-232C	Measurement control and data output with computer, direct output to printer
Power supply		AAA-size battery x 2 or AC adapter
Temperature, humidity range		-10 °C to 500 °C, 30% to 90% RH (there should be no dew condensation)
Dynamic characteristics		Fast, Slow
Size (HXWXD)		168 × 48 × 23.5 mm
Weight		Approx. 125 g (incl. battery)

Volume Indicator Stand

Use is possible from a height of 190 mm to 1,000 mm. 50 cm, 45° measurement setting can be performed in one go with the arrow mark on the end.

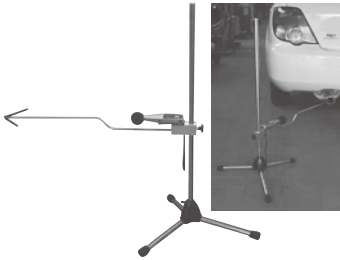

Part No.	KNK-9-STAND	ALH050411-001
Product name	Volume stand	Noise meter stand
Supported measuring instruments	NL26/NL27	IM2801
Measurement height (mm)	50 to 1,500	190 to 1,000

Sound Checker (Non-certified Product)

KN-9-SL4010



- 38 to 130 dB covered with a single checker.
- Support for 31.5Hz to 8kHz
- With data hold function

Display	3.5-digit LCD display
Measurement range	35 to 80 dB/50 to 100 dB/80 to 130 dB
Frequency range	31.5 to 8kHz
Resolution	0.1 dB
Measurement accuracy	± (4% rdg + 3 dig) (at 50/60Hz)
Power supply	006P (9 V) × 1
Size, weight	70 (W) × 225 (H) × 28 (D) mm, approx. 250 g

Radiator Liquid Storage Tank

KP-1-PL100



Lightweight. (Made of approx. 50% steel)
Excellent durability. (Long life with twice the strength of those made of steel)
Rust-resistant.
Excellent chemical and oil resistance.
Excellent impact strength, with the restoring force not found in steel.

Size: φ480 × 715 (H)
Capacity: 100 L
Color: Gray

Fuel Tank Protective Cover

KP-7-3



To prevent scratches while working.
For medium-size and large bikes.

Oil Water Separating Layer

KP-1-10

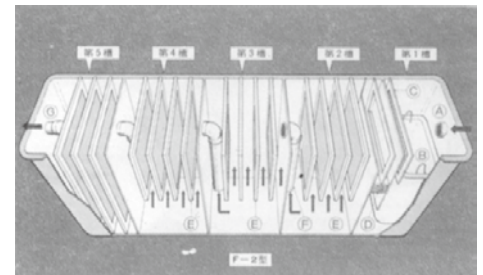

Underground type FRP
Top cover: Iron 6 mm
* Construction costs are charged separately.

Diagnostic Instruments/Tools for Improving Work Environment

Stud Bolt Setter

Set fo 4 KL-14-4203M



<Sold individually>

KL-14-4103M6	6 mm
KL-14-4103M8	8 mm
KL-14-4103M10	10 mm
KL-14-4103M12	12 mm

Tap Die Set

KM-2-M20B

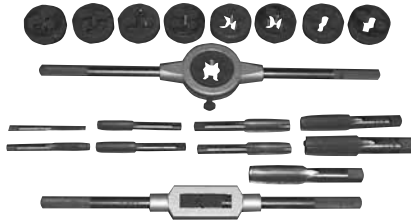

Set contents:
Taps and dies
3×0.5 4×0.7 5×0.8 6×1.0 8×1.25
10×1.25 10×1.5 12×1.25 12×1.5
Tap wrench and die handle, 1 of each

Recoil Quick Center Set

KM-5-QCME68107



Recoil Kit

Ultimate solution for reproducing female screws
Female screws can be repaired easily.
Kit contents: Tap with pilot, insertion tool, packet
(Drills for preparation holes are sold separately.)



Part No.	Part Name	Model
KM-5-101	Recoil Kit M8 × 1.25	No.35080
KM-5-101L	Recoil Kit M10 × 1.25	No.37100
KM-5-102	Recoil Kit M12 × 1.50	No.37120
KM-5-103	Recoil Kit M14 × 1.50	No.37140
KM-5-105	Recoil Kit for Left Screws M8 × 1.25	No.35080LH
KM-5-90	Recoil Kit for Spark Plugs M10 × 1.0	No.38100
KM-5-91	Recoil Kit for Spark Plugs M12 × 1.25	No.38120
KM-5-93	Recoil Kit for Spark Plugs M14 × 1.25	No.38147

Recoil Kit with Pilot Tap

Prepared hole machining and tapping can be performed simultaneously.
Comes with a tap that requires no prepared hole drill.



Kit contents: Tap with pilot, insertion tool, packet

Part No.	Part Name	Model
KM-5-110	Recoil Kit with Pilot Tap M6 × 1.0	No.35063
KM-5-111	Recoil Kit with Pilot Tap M8 × 1.25	No.35083
KM-5-112	Recoil Kit with Pilot Tap M10 × 1.25	No.37103
KM-5-117	Recoil Kit with Pilot Tap M12 × .50	No.37123
KM-5-123	Recoil Kit with Pilot Tap M14 × 1.5	No.37143

Range Kit



This is a recoil kit assorted product. This kit contains a combination of frequently used sizes based on the usage purpose.

Part No.	Part Name	Model
KM-5-114	Range Kit Set of 3 M6, M8 × 1.25, M10 × 1.25	No.37002
KM-5-115	Range Kit Set of 6 M6, M8 × 1.25, M10 × 1.25 M10 × 1.0, M12 × 1.25, M14 × 1.25	No.38006
KM-5-115PN	Mini Range Kit with Pilot Tap Set of 6	No.38006PN

Recoil Packet (Spare Packets)



Part No.	Part Name	Model	Qty/ packet
KM-5-250	Recoil Packet M6 × 1.0	No.25063	10
KM-5-270	Recoil Packet M8 × 1.25	No.25083	10
KM-5-270L	Recoil Packet M8 × 1.25	No.25083LH	10
KM-5-300	Recoil Packet M10 × 1.25	No.27103	10
KM-5-301	Recoil Packet M10 × 1.0	No.28103	10
KM-5-331	Recoil Packet M12 × 1.25	No.28123	10
KM-5-332	Recoil Packet M12 × 1.50	No.27123	10
KM-5-361	Recoil Packet M14 × 1.25	No.28140	5
KM-5-362	Recoil Packet M14 × 1.50	No.27143	5

Die Holder

KMK-2-HLDR25



- Applicable die external shape: 25 mm
(Size: 2 to 12 mm)
- * Applicable dies are sold separately.

For muffler attachment, stud bolt screw thread repair, etc.

Drill Set

KM-1-2



Set contents: 1 to 10 mm
0.5 mm intervals Set of 19

Deburring Tool

KM-2-NB5000



Hole and edge deburring
(blue handle)

Step Drill

For use with power drills used for drilling various sizes of hole, and for enlarging or repairing holes
Hex shank
(Rechargeable drills of 12 V or higher)
Step drill



Part No.	KM-ESD-412	KM-ESD-422
Model	ESD-412	ESD-422
Drilling size (φ)	4, 5, 6, 7, 8, 9, 10, 11, 12	4, 6, 8, 10, 12, 14, 16, 18, 20, 22
Span pitch	3	5
Number of steps	9	10
Total length L (mm)	65	85

Rotary Cutter

KM-6-1



Used to enlarge holes in urethane material, etc.
* Use with a Leutor or power drill.

The KOWA logo is centered in the middle of the page. It consists of the word "KOWA" in a bold, white, sans-serif font, enclosed within a white oval border. The background of the entire page is a dark blue gradient with a repeating pattern of stylized, interconnected shapes that resemble a honeycomb or a mesh structure. A bright blue light source from the left creates a lens flare effect, with a diagonal line of light crossing the page from the top-left towards the bottom-right. In the bottom right corner, there is a solid white rectangular area.

KOWA